

# COMPETITION RULES, REGULATIONS, PROCEDURES & BY-LAWS 2023



## **BADGER KART CLUB MISSION STATEMENT**

We will provide our members and guests with a safe and family friendly racing experience by enforcing good sportsmanship and fair competition. By doing so, we will promote the sport of go kart racing, increase our club membership, and build awareness of the positive impact that takes place in the lives of those who participate.

### **TIRE TREATING IS PROHIBITED**

Only untreated tires are allowed. No altering of any kind is allowed. Wire brushing or scraping to remove debris or rubber build up is allowed. **The penalty for violating the tire-treatment ban will be a suspension for 30 days or the next two BKC points races, whichever is greater, including non-race/practice days.** Suspension days cannot be used as drop races.

### **VOLUNTEER WORKDAYS ARE NOT REQUIRED FOR 2023**

### **CIK BODYWORK REQUIRED FOR ALL CLASSES IN 2023**

CIK bodywork required in all classes. Pushback front bumpers required in 2-cycle classes.

#### **Prologue**

These Rules, Regulations and Procedures were ratified by the Badger Kart Club General Membership on Sunday, February 5th, 2023, and are in effect as of that date, superseding any and all other “Rules, Regulations and Procedures” in effect prior to that date.

These Rules, Regulations and Procedures will remain in effect until such time as the Badger Kart Club General Membership approves a new set of “Rules, Regulations and Procedures” according to the procedures as set forth in the current Badger Kart Club’s By-Laws.

#### **Purpose of these Rules**

The purpose of these rules and regulations is to provide a minimum set of acceptable standards and requirements to that Badger Kart Club’s (BKC) racing events can be conducted in a safe, fair, orderly, and competitive manner for the enjoyment of all participants.

To achieve this, an understanding and adherence to these rules and regulations as set forth in this rulebook, and any supplemental rules and regulations, by all BKC members, is fundamental to the welfare of everyone and will be enforced by all BKC officials.

These rules and regulations shall cover the conditions of all BKC events. As all BKC members, drivers and participants in general, are required to understand and be fully conversant with these rules and regulations, as well as any supplemental rules or instructions, by participating in any BKC event and member, driver, or participant in general, thereby accepts these rules and regulations and agrees to comply and be bound by same.

No express or implied warranty of safety shall result from publication of, or compliance with these rules and/or regulations. They are intended as a guide for the conduct of the sport and in no way guarantee against injury or death to participants, spectators, or others.

# Table of Contents

**Table of Contents**..... 1  
**Prologue**..... 4  
**Purpose of these Rules**  
**Competition Rules Committee**

**1. GENERAL RULES** ..... 5  
 1.1 Rules to be used  
**1.2 Membership Requirements**  
 1.2.1 Valid Membership ..... 5  
 1.2.2 Understanding the Rules ..... 5  
**1.3 Violation of Rules**  
 1.3.1 Violation of Requirements ..... 5  
 1.3.2 Suspension ..... 5  
**1.4 Disciplinary Actions**  
**1.5 Protests**  
**1.6 Appeals**  
 1.6.1 Exceptions to Appeal Process ..... 6  
**1.7 Age Definitions**  
 1.7.1 Legal Competition Age ..... 6  
 1.7.2 Junior Age Option ..... 6  
**1.8 Parental Permission**  
 1.8.1 Adult Presence Required ..... 6  
**1.9 Waivers and Fees**  
 1.9.1 Minor's Release ..... 6  
**1.10 Refunds**  
 1.10.1 Race Day Refunds ..... 6  
 1.10.2 Practice Day Refunds ..... 6  
**1.11 Pit Restrictions**  
**1.12 Use of the Facilities**  
 1.12.1 Days of Operation ..... 6  
 1.12.2 Hours of Operation ..... 6  
 1.12.3 Conditions ..... 7  
 1.12.4 Consideration for the Neighbors ..... 7  
 1.12.5 Extended Usage ..... 7  
 1.12.6 Caretaker ..... 7  
**1.13 Practice Days**

**2. OFFICIALS** ..... 7  
**2.1 Race Committee Duties**  
 2.1.1 Race Director's Duties ..... 7  
 2.1.2 Tech Inspector's Duties ..... 7  
 2.1.3 Flagperson's Duties ..... 7  
 2.1.4 Corner Workers ..... 7

**3. PERSONAL CONDUCT AND DRIVING RULES** 8  
**3.1 Overall Responsibility**  
**3.2 Unsportsmanlike Conduct**  
 3.2.1 Social Media ..... 8  
 3.2.2 Appear before the BKC Board of Directors ... 8  
**3.3 Spirit and Intent**  
**3.4 Driving Responsibilities and Conduct**  
 3.4.1 Start Responsibilities ..... 8  
 3.4.2 Start Zone ..... 8  
 3.4.2.4 No Passing in Start Zone ..... 8  
 3.4.3 Entering After the Start ..... 8  
 3.4.4 Pit Stops ..... 8

3.4.5 Driving in the Pits ..... 8  
 3.4.6 "Track" Defined ..... 8  
 3.4.7 Driving Infractions ..... 9  
 3.4.8 Penalties ..... 9  
 3.4.9 Waived Penalties ..... 10  
 3.4.10 Restarting engine after start of race ..... 10  
 3.4.11 No Racing After Checkered Flag ..... 10  
**3.5 Safety Conduct**  
 3.5.1 Mandatory Driver Personal Protection ..... 10  
 3.5.2 Smoking or Open Flame ..... 10  
**3.6 Participation and Involvement**  
**3.7 Skill and Conduct**  
 3.7.1 Rookie Number Panels ..... 10  
**3.8 Officials Policy**  
 3.8.1 Officials policy penalty ..... 11  
 3.8.2 Discussions with Officials ..... 11

**4. RACE PROCEDURES AND RULES** ..... 11  
**4.1 Event Considered Official**  
**4.2 Rain Out**  
**4.3 Legal Entrant**  
**4.4 Pre-Tech Safety Inspection**  
**4.5 Sound Test**  
 4.5.1 Practice ..... 11  
 4.5.2 Race ..... 11  
**4.6 Track Records/Fast Time for the Year**  
 4.6.1 Eligibility ..... 11  
 4.6.2 Certification ..... 11  
 4.6.3 Standing Track Record ..... 11  
**4.7 Drivers Meeting**  
**4.8 "90-Second Rule"**  
**4.9 Race Details**  
 4.9.1 Heat Race Format ..... 11  
 4.9.2 Combined Classes ..... 12  
 4.9.3 Qualifying Format ..... 12  
 4.9.4 Ties in Electronic Scoring ..... 12  
**4.10 Post Tech/Weigh-In**  
 4.10.1 Crewmembers ..... 12  
**4.11 Designated Driving Areas**  
**4.12 Expert Class Option**  
**4.13 Loss of Exhaust System**  
**4.14 Finish Restrictions**  
**4.15 Replacement/Change/Alteration / switching Restrictions**  
 4.15.1 Driver Restrictions ..... 13  
 4.15.2 Equipment Restrictions ..... 13  
**4.16 Accident Requirements**  
 4.16.1 Inspection ..... 13  
 4.16.2 Red Flag ..... 13  
**4.17 Loss of Brakes**  
**4.18 Fuel/Oil and Other Fluids**  
 4.18.1 Spills ..... 13  
 4.18.2 Fluids or Waste Material Collection and Disposal ..... 13  
**4.19 Flags Displayed by the Flag Person**  
 4.19.1 Green Flag ..... 14  
 4.19.2 Yellow Flag ..... 14  
 4.19.3 Red Flag ..... 14  
 4.19.4 White Flag ..... 14  
 4.19.5 Black Flag Waving ..... 14



## *Badger Kart Club Rules and Procedures*

4.19.6 Black Flag with Orange Disc (Meatball Flag)	14
4.19.7 Rolled Black Flag	14
4.19.8 Blue Flag with Orange Sash	14
4.19.9 Checkered Flag	14
4.19.10 Black and Checkered Flags	14

### **5. MG TIRES CHAMPIONSHIP POINTS SERIES**15

#### **5.1 Eligibility**

5.1.1 Legal Entrant	15
5.1.2 Attendance	15
5.1.3 Rain Outs	15
5.1.4 Bye Week Requirements	15

#### **5.2 Championship Points Details**

5.2.1 Tie	15
5.2.2 Point Standings	15

Discrepancies in championship points cannot be contested after 2 weeks from the time of posting on the BKC Website. There will be no exceptions.

5.3 Year-End Awards	15
---------------------	----

### **6. COMPETITION CLASS REQUIREMENTS**..... 16

#### **6.1 Briggs 206 Cadet**

6.1.1 Age	16
6.1.2 Engines/Fuel/Weight	16
6.1.3 Tire Spec	16
6.1.4 Miscellaneous	16

#### **6.2 Briggs 206 Sportsman**

6.2.1 Age	16
6.2.2 Engines/Fuel/Weight	16
6.2.3 Tire Spec	16
6.2.4 Miscellaneous	16

#### **6.3 Mini Swift**

6.3.1 Age	16
6.3.2 Engines/Fuel/Weight	16
6.3.3 Bodywork	16
6.3.4 Tire Spec	16
6.3.5 Miscellaneous	16

#### **6.4 Briggs 206 Junior**

6.4.1 Age	16
6.4.2 Engines/Fuel/Weight	16
6.4.3 Tire Spec	16
6.4.4 Miscellaneous	16

#### **6.5 IAME 100 Junior**

6.5.1 Age	16
6.5.2 Engines/Fuel/Weight	16
6.5.3 Bodywork	16
6.5.3 Tire Spec	16
6.5.5 Miscellaneous	16

#### **6.6 Briggs Senior Medium**

6.6.1 Age	16
6.6.2 Engines/Fuel/Weight	16
6.6.3 Tire Spec	16
6.6.4 Miscellaneous	16

#### **6.7 Briggs Senior Heavy**

6.7.1 Age	17
6.7.2 Engines/Fuel/Weight	17
6.7.3 Tire Spec	17
6.7.4 Miscellaneous	17

#### **6.8 Yamaha Senior**

6.8.1 Age	17
6.8.2 Engines/Fuel/Weight	17
6.8.3 Bodywork	17
6.8.4 Tire Spec	17
6.8.5 Miscellaneous	17

#### **6.9 TaG 100 Senior**

6.9.1 Age	17
6.9.2 Engines/Fuel/Weight	17
6.9.3 Bodywork	17
6.9.4 Tire Spec	17
6.9.5 Miscellaneous	17

#### **6.10 Expert**

6.10.1 Age	17
6.10.2 Requirements	17

### **7. COMPETITION EQUIPMENT** ..... 18

#### **REQUIREMENTS**..... 18

##### **7.1 General Requirements**

7.1.1 Sound Limitations	18
7.2 Engine and Equipment Requirements	18
7.2.1 Claiming	18
7.2.2 Engine Tech	18
7.2.3 Engine Legality	18
7.2.4 "Stock" Defined	18
7.2.5 Briggs Stock 4-Cycle Defined	18
7.2.6 Muffler Requirements	18
7.2.7 Restrictors Defined	18
7.2.8 Clutches	18
7.2.9 Clutch Guard	18
7.2.10 Carburetor	18

##### **7.3 Fuel and Fuel System**

7.3.1 Fuel System Security	19
7.3.2 4-Cycle Fuel	19
7.3.3 4-Cycle Fuel Test Procedure	19
7.3.4 2-Cycle Fuel Test Procedure	19
7.3.5 Fuel Test Protest	19

##### **7.4 Kart and Equipment Requirements**

###### **7.4.1 Required Equipment Specifications** 19

7.4.2 Bodywork	19
7.4.3 Spindle Nuts	20
7.4.4 Ballast/Weight	20
7.4.5 Brakes	20
7.4.6 Chain Guard	20
7.4.7 Chain Oiler	20
7.4.8 Driver's Compartment	20
7.4.9 Unwanted Projections	21
7.4.10 Gearbox	21
7.4.11 Number Identification	21
7.4.12 Seat and Floor Plan	21
7.4.13 No Seat Belts	21
7.4.14 Seat Struts	21
7.4.15 Sprockets – Exposed	21
7.4.16 Steering	21
7.4.17 Throttle	21
7.4.18 Monitoring Devices/Radios	21

###### **7.5 Tires**

7.5.1 Requirements	21
7.5.2 Tire Exceptions	21
7.5.3 Rain Tires	21
7.5.4 Tire Treating Prohibited	21



7.5.5 Tire Testing .....21  
**7.6 Transponders**  
**7.6.1 Usage**  
7.6.1 Mounting .....21  
**7.7 Kid Kart**  
7.7.1 Age.....22  
7.7.2 Kart Specifications .....22  
7.7.3 Engine.....22  
7.7.4 Kid Kart Race Format .....22

**DAVIDHOBBS** Honda  
DEALER FOR THE PEOPLE



**JUNE**   **JULY**   **AUGUST**  
**4,10,11**   **16,29,30**   **20,27**

# Wisconsin State Championship



**Round 1 & 2**  
**July 1-3, 2023**

**Round 3 & 4**  
**August 4-6, 2023**

## CLASSES

Briggs 206 Sportsman  
Briggs 206 Junior  
Briggs 206 Senior  
Yamaha Senior Pipe

TaG Senior 100cc (KA & VLR)  
TaG Masters 100cc (KA & VLR)  
IAME KA Junior  
IAME Mini Swift

## EVENT HIGHLIGHTS

Qualifying / Multiple Heat / Final Format  
20 Lap Finals for Senior Classes, 16 Lap Finals for Junior Classes  
Saturday Cookout for all Competitors and Family



SCAN ME



# **1. GENERAL RULES**

## **1.1 Rules to be used**

All persons on Badger Kart Club's (BKC) premises or at any BKC event will follow all rules, regulations, and safety requirements set forth by the Badger Kart Club. World Karting Association (hereinafter WKA) rules pertaining to safety and kart and engine specifications will prevail unless otherwise specified herein. (WKA Rules are available as part of WKA's published Technical Manual.)

### **1.1.2 Spirit and Intent**

It is the requirement of all Badger Kart Club members and users of Mill-Rite Raceway to conduct themselves at all times within the Spirit and Intent of these rules and regulations, both as specifically stated and as implied. No pretense is made of having designed a foolproof set of rules and regulations. Any person who falsifies his/her requirements or modifies his/her equipment in an attempt to defraud BKC officials, other competitors, or the members of Badger Kart Club, intending to circumvent or undermine these rules, the family sport of competitive karting, or Badger Kart Club in anyway, as determined by the Race Committee or BKC Board of Directors, can be disqualified from the event. That person(s) will be required to leave the facility and be subject to further disciplinary action.

The BKC Race Committee and/or BKC Board of Directors shall have the right to initiate such action correcting a hazardous condition or a condition not in compliance with the Spirit and Intent of these regulations.

## **1.2 Membership Requirements**

### **1.2.1 Valid Membership**

For membership to be valid and to receive member benefits, all of the proper membership, waivers of liability, proof of age, and EMT forms must be accurately completed and on file with BKC for all family member participants, and all fees must be paid.

### **1.2.2 Understanding the Rules**

All members, drivers, and participants in general, are required to understand and be fully conversant with these rules and regulations, as well as any supplemental rules, regulations, or instructions imposed and necessary.

## **1.3 Violation of Rules**

Any competitor determined to be in violation of the rules as set forth, with the intent to compete illegally or with the intent to defraud officials or other competitors by such modifications, unsportsmanlike driving or conduct, or flagrant violation of a rule to gain an unfair advantage, may be subjected to appropriate disciplinary action as determined by the Race Committee or BKC Board of Directors.

### **1.3.1 Violation of Requirements**

Any competitor not meeting requirements for legality will be restricted from and/or disqualified from competition. Competition in subsequent heats will be permitted once the rule violation is corrected. All questions concerning violations or alleged violation of a rule by a competitor shall be referred to the Race Director for determination if the competitor then meets class rules.

### **1.3.1.1 Disqualification Penalties**

Any competitor found to be in violation of requirements for legality at the conclusion of a race day's events will be disqualified for that day in that class.

### **1.3.1.2 Exceptions**

Failure to complete a race due to breakage, collision, or mechanical black flag due to a collision or mechanical breakdown will not be considered a disqualification for that day (see rule 4.9.1.5).

### **1.3.1.3 Required Board Review**

Following the third disqualification of a competitor in a season, the BKC Board of Directors shall review the competitor's violations.

## **1.3.2 Suspension**

Any competitor who is in constant violation of the rules as set forth will be subject to suspension upon review of all evidence by the BKC Board of Directors.

## **1.4 Disciplinary Actions**

The BKC Board of Directors may, at its own discretion or on the recommendation from any of its officers or appointed officials, initiate disciplinary actions against any participant's infraction(s) of the BKC Rules and Regulations as listed herein.

## **1.5 Protests**

Any competitor has the right to protest any action by another competitor or race official. Protests, in order to be considered, must meet the following requirements:

- **All protests must be submitted to a member of the Race Committee of the event within 30 minutes after the protested infraction or announced decision.**
- A \$100.00 fee, refundable only if the protest is upheld, must accompany all protests.
- All protests must be submitted by a legal entrant in the class the protest concerns (See Rule 4.3).
- **All protests must be written on a BKC Protest Form and clearly define the offense with respect to the rule as listed in the current WKA rules (or as specifically superseded herein) allegedly violated.**
- No video or photographic images will be allowed as evidence for a protest.
- The BKC Board of Directors or Race Committee is not required to consider any protest in an open meeting.
- The race committee will make every effort to reach a decision on a protest before the completion of the day's activities. The only exception is if the Race Committee notifies the protestor, before the completion of the day's activities, that the protest is being referred to the BKC Board of Directors for final decision, at its next regularly scheduled meeting.
- The decision of the Race Committee or Board of Directors on any protest is final, subject to appeal
- (See "Appeals" Rule 1.6).

## **1.6 Appeals**

Any member may appeal a decision MADE ON A PROTEST that they feel has been made in error unjustly. This Appeal will be made to and resolved by the BKC Board of Directors. An Appeal, in order to be considered, must meet the following requirements:

- Any member may appeal the decision of a protest whether they are directly or indirectly affected by that decision. Only



the decision of the protest may be appealed. It is intended that the appeal process take place only after the full protest process has been exhausted.

- An Appeal must be made in writing and presented to a member of the BKC Board of Directors at least one week prior to their next regularly scheduled board meeting.
- If the time of the appeal occurs less than one week prior to the next regularly scheduled board meeting, the board has the option not to hear the appeal for two (2) regularly scheduled board meetings from that date. The written Appeal must describe the issue in detail and include all necessary considerations.
- The Appeal must request in detail any and all actions the petitioner requests.
- The BKC Board of Directors, by its own decision and for whatever reasons, may refuse to consider an appeal.
- No video or photographic images will be allowed as evidence for an appeal.
- The BKC Board of Directors is not required to consider any appeal in an open meeting.
- An appeal can only be made to the Board of Directors and the Board's outcome of any appeal is final.

#### **1.6.1 Exceptions to Appeal Process**

The only exception will be where a disciplinary action has been taken directly by the Race Committee or the Board of Directors. In this case, an appeal will be allowed directly to the Board of Directors, without the protest process, providing all provisions listed above (see Rule 1.6) are followed.

### **1.7 Age Definitions**

#### **1.7.1 Legal Competition Age**

With the exception of the Kid Kart drivers, no individual less than seven (7) years of age may operate a kart on BKC property. Unless otherwise noted, a driver's actual age between December 25, 2022, to December 24, 2023 shall establish their "competition age" for the competition year.

#### **1.7.2 Junior Age Options**

##### **1.7.2.1 Junior Achieves Age**

A driver who reaches an age making them eligible for another class may take the option of remaining in the lower-aged classes for the remainder of that year.

##### **1.7.2.2 Juniors moving up to Senior classes**

If a Junior class driver moves up to a Senior class, they may not continue to compete in both classes or return to a Junior class after taking part in any Senior class event (BKC events only) without approval of the Board of Directors.

##### **1.7.2.3 Sportsman or Cadet Classes**

Any driver who chooses to move up in junior class may not continue to compete in both classes or move back to the Sportsman class without approval of the Board of Directors.

##### **1.7.2.4 LO206 Cadet**

Past year champion must move out of class.

### **1.8 Parental Permission**

All BKC participants, up to the age of 18, must have their parent or guardian's written permission, a copy of their birth certificate (or other proof of age), a minor release and an EMT form on file with BKC. Proof of age is required prior to use of BKC facilities.

#### **1.8.1 Adult Presence Required**

During the operation of a kart at BKC, any Junior driver under the age of 14 must be accompanied by a parent or legal guardian, age 18 or over. This person must also purchase a pit pass in order for the Junior driver to be on the track.

##### **1.8.1.2 Minor Injured**

In the case where a minor is present with only a legal guardian (parents are not present) and that minor is injured and requires medical treatment and/or transportation (per medical personnel) to a medical facility, it is required that the minor receive treatment and/or transportation regardless of the directions of the legal guardian.

### **1.9 Waivers and Fees**

All competitors must sign all waivers of liability and pay all required fees before operating their equipment at Mill-Rite Raceway for a race or for practice.

#### **1.9.1 Minor's Release**

Any minor using BKC must have a minor's release on file for pit entrance, practice or race, signed by a parent or legal guardian.

### **1.10 Refunds**

#### **1.10.1 Race Day Refunds**

No refunds will be made on race day.

#### **1.10.2 Practice Day Refunds**

No practice refunds will be made.

### **1.11 Pit Restrictions**

No vehicles, trailers, or campers will be allowed in the pits at any time, without specific authorization. No pitting inside the fenced-in pit area.

Operation of any non-registered motorized vehicles is prohibited on BKC grounds. Registered vehicles may be operated by *licensed drivers* only.

No scooters, skateboards, bicycles, electric scooters, etc., are allowed in the pits on race days from 8am to 6pm.

### **1.12 Use of the Facilities**

All participants will abide by any rule or regulation, permanent or temporary, imposed on BKC by any Federal, State, County or local municipality. Any deviations from these rules will be grounds for refusal of any future use of the facilities.

#### **1.12.1 Days of Operation**

All participants will follow any and all regulations having to do with the track being closed certain weekdays and scheduled weekends throughout the year.

#### **1.12.2 Hours of Operation**

All participants will follow any and all regulations having to do with the track being closed certain scheduled time periods during the day.

The Mill-Rite Raceway premises must be vacated by 9:00 pm on Sundays.

#### **1.12.3 Conditions**

No practice will be allowed when the track is deemed unsafe, by caretaker or BKC official(s).

#### **1.12.4 Consideration for the Neighbors**

All participants will conduct themselves in a quiet and respectable manner, both at the track, on the way in, and on the way out, as well as anywhere in the area, to respect the neighbors and other local resident's privacy. Fireworks are strictly prohibited.

#### **1.12.5 Extended Usage**

No vehicles, trailers and/or campers will be allowed to park more than five (5) consecutive days on Mill-Rite Raceway premises without specific authorization.

#### **1.12.6 Caretaker**

The Caretaker has the authority, on behalf of BKC, to revoke a pit pass and/or refuse the use of the facilities to any individual who does not abide by any rule or regulation of BKC. This authority also applies to any BKC Officer or Board Member.

#### **1.13 Practice Days**

Other guidelines and procedures may be posted on BKC website or implemented at the facility regarding practice and must be followed.

## **2. OFFICIALS**

### **2.1 Race Committee Duties**

It is the duty of the Race Committee (which consists of the Race Director, Flagman, and Chief Tech Inspector) to carry out and enforce the rules of BKC. All violations or irregularities, be they on or off the track, are to be reported to the Race Committee. The Race Committee shall have the power to disqualify anyone, who in their opinion, is in violation of the rules. Their decision shall be final for the day. Race Committee personnel may only perform one duty on any single race day.

#### **2.1.1 Race Director's Duties**

The Race Director shall have complete charge of the day's event. All other officials are to report directly to them. The Race Director shall enforce the rules of BKC. The Race Director shall report any major infraction or disagreements to the BKC Board of Directors at their next regular meeting for possible further action. The Race Director has the right to appoint anyone else they feel is necessary to help in the running of any BKC event. The Race Director can, with Race Committee approval, require any competitor to change a competition class or refrain from active competition, with respect to that competitor's abilities.

#### **2.1.2 Tech Inspector's Duties**

The Tech Inspector is responsible for the interpretation and enforcement of all technical rules. The Tech Inspector shall supervise all teardowns, fuel checks, and other questions of equipment legality. The Tech Inspector has complete authority to tech any competitor or any equipment at any time. The Tech Inspector's decisions are to be obeyed without exception, subject to disqualification and/or suspension.

#### **2.1.3 Flag Person's Duties**

The Flag Person shall have complete charge of the racetrack during the running of an event. Their flag signals are to be obeyed without exception, subject to disqualification.

### **2.1.4 Corner Workers**

The Corner Workers will have the authority to use a yellow flag to alert and warn drivers of possible dangers and will also have the duty to inform the Flagman or Race Director of any unsafe track conditions or observed driving infractions.

#### **2.1.4.1 Corner Worker Guidelines**

##### **2.1.4.1.1 Corner Worker Priorities**

The corner worker's first priority is their safety and that of other corner workers. The second priority is the safety of the racers still running on the track. The third priority is the safety of the racers involved in the incident. The fourth priority is removal of any stalled karts or other debris on the racing surface that may pose a hazard.

##### **2.1.4.1.2 Area of Responsibility**

The Corner Worker's "area of responsibility" is from their flagging position to the next "down track" (race direction) flagging post. Should an incident occur 60' in front of your position, it is not appropriate for you to flag the incident. The proper response would be to call the "up track" station and ask for the appropriate flag to be displayed, or to visually confirm it is displayed. Once racers have passed your station, you would then assist racers in the incident as needed. Do not abandon your flagging station while there are oncoming karts on the course.

##### **2.1.4.1.3 Flagging the Corner**

Position yourself so that you will not be in harm's way, are far enough up the track from the corner to warn drivers of an unsafe condition, and so you can see through your corner to the next corner worker, if possible. Do not turn your back on oncoming traffic when close to the track, and do not cross or approach the track until all traffic has passed.

Corner worker at BKC will only be using a yellow flag. There are three levels of yellow flag conditions; "furlled and pointed" at a marginal condition, such as a disabled kart of the track on a straight; "stationary," held perpendicular to the racers line of sight at waist level for things such as a disabled kart on track but off the racing line or a kart off track in a curve, and "waving" in a figure eight pattern perpendicular to the racers line of sight from shoulder to waist level when the racing line is blocked. **(See rule 4.19.2. Yellow Flag for further clarification).**

Be alert! Do not become part of the situation. In any incident, try to remember the sequence of the events, making a mental note of what happened, to report to the flagman, or for a medical report if it becomes necessary. Begin by warning oncoming drivers by displaying the appropriate flag: furlled pointed, stationary, or waving. Request emergency personnel or equipment if needed. At no time is a corner worker to move an injured driver. If the driver is uninjured, instruct them to move themselves and their kart (when feasible), to a safe area. You may assist them as needed once there are on more oncoming karts. Remember, your safety and warning oncoming drivers are your first two priorities.

Report any unsafe track conditions, passing under a standing/waving yellow, or other driving infractions to the flagman by radio. If you do not have radio contact, get the information to the lead corner worker immediately after that race.

## **3. PERSONAL CONDUCT AND DRIVING RULES**

Immediate disqualification and/or suspension, determined by the Race Committee or BKC Board of Directors, may be enacted for any infraction(s) of a personal conduct or driving rule(s). Any BKC Official, Officer, Race Committee member, or member of the Board of Directors can initiate such action by bringing it before the Race Committee or BKC Board of Directors.

### **3.1 Overall Responsibility**

The driver is always the Legal Entrant (see Rule 4.3).

The driver (Legal Entrant) is, at all times, responsible for the legality of their equipment and is required to be fully conversant and answerable to these regulations and any supplementary rules and regulations governing an event and is bound by such regulations, supplementary rules, or instructions.

The driver (Legal Entrant) will at all times be responsible for their own conduct, and that of their crew(s) and guest(s).

### **3.2 Unsportsmanlike Conduct**

Badger Kart Club members have set a high standard for sportsmanship and family atmosphere both at and away from the track. Unsportsmanlike conduct including, but not limited to, abusive and/or foul language, fighting, or refused cooperation will not be tolerated. Anyone exhibiting such conduct can be disqualified from an event, required to leave the facility, and be subject to further disciplinary action.

#### **3.2.1 Social Media**

Posts on blogs or social media sites such as Facebook and Twitter that reflect poorly on Badger Kart Club, fellow competitors, and/or the sport of karting are unacceptable and may result in disciplinary action at the discretion of the Board of Directors. Differences of opinion regarding BKC rules and regulations, decisions by BKC officials, BKC policies, or between competitors are best handled privately and directly between the parties involved. Penalties for violations may include suspension from BKC competition.

#### **3.2.2 Appear before the BKC Board of Directors**

Any person or family that has been ejected from Badger Raceway or any BKC event, or suspended from BKC competition due to unsportsmanlike conduct, including conduct on internet sites and blatant tech violations as seen fit by the Head of Tech, shall be required to appear before the BKC Board of Directors before they may attend/race/practice at any future Badger Kart Club event again. A letter explaining this *may* be sent to the ejected party. However, failure to send or receive this letter is in no way excuses the ejected party from this mandatory meeting.

The purpose of the meeting is for the penalized person(s) to explain to the board how they intend not to violate the rules in the future. It is up to the Board's discretion as whether to allow the penalized person(s) to continue racing at Badger Raceway.

##### **3.2.1.1 Scheduled race before board meeting**

If there is another scheduled BKC Championship points race before the next scheduled board meeting, the BKC Board of Directors can organize a special-purpose meeting to discuss the ejection. This can be held at the track or

another facility and is for the "convenience" of the penalized party, not the board of directors.

## **3.4 Driving Responsibilities and Conduct**

### **3.4.1 Start Responsibilities**

#### **3.4.1.1 Pre-race**

Karts will leave the grid and reform up into their assigned positions immediately. Karts will proceed slowly around the outside of the track, maintaining grid positions. Karts will proceed slowly and remain in gridded positions until green flag is displayed. (see rule 3.4.3 for additional information).

### **3.4.2 Start Zone**

#### **3.4.2.1 Definition**

Cones will be placed on both sides of the track (possibly both sides) before the start/finish line. Distance from the cone to the start/finish line will be determined by the Race Director and may change during the racing season at the discretion of the Race Director. A line will be marked down the center of the track.

#### **3.4.2.2 Use of Start Zone**

During a green flag start, the flag person may wave the green flag to start the race any time after the front row has entered the start zone. The flag person may not throw the green flag after the front row leaves the start zone.

#### **3.4.2.3 Start Pace**

The pole-position driver must set a reasonable pace and lead the field to the green flag at a slow, controlled pace. If any kart on the front row cannot set or keep a reasonable pace, the Flagman may invert that kart to the second row.

#### **3.4.2.4 No Passing**

During a green flag start, no driver may pass until exiting the start zone. A driver may not pass the back bumper of the drivers that are gridded in front of them until leaving the start zone. Drivers must stay on their side of the track as indicated by the line in the center of the start zone.

#### **3.4.2.5 Penalty**

Violation of the No Passing rule will result in the loss of one position and one additional position for each kart passed (to be assessed upon completion of the heat race or feature that infraction occurred in).

### **3.4.3 Entering After the Start**

Except for Sportsman and Kid Kart classes, no kart will be permitted to enter a race once the race is underway.

### **3.4.4 Pit Stops**

Pit stops are NOT allowed during races.

### **3.4.5 Driving in the Pits**

There will be absolutely no driving of karts in the pit area past the line before the scale at any time, engine running or not, except as specifically authorized by the Race Director. No kart shall be set in motion south of the scoring tower bridge.

### **3.4.6 "Track" Defined**

The track is the entire paved area of the course, including the curbs and paved areas past the curbs. A competitor will



be judged to have left the track if no part of the kart remains in contact with the track.

### **3.4.7 Driving Infractions**

#### **3.4.7.1 Blocking**

A competitor may not alter their racing line in response to pursuing drivers. More than one change of direction to defend a position is prohibited.

#### **3.4.7.2 Avoidable Contact / Causing a Collision**

The primary responsibility for avoiding contact lies with the overtaking or trailing competitor and the secondary responsibility lies with the competitor(s) being overtaken or leading competitor. A competitor who initiates a maneuver that results in contact with another competitor may be penalized. Contact behind the driver is generally considered avoidable contact by the trailing kart. Where two karts are reasonably alongside each other, each must permit the other racing room.

#### **3.4.7.3 Leaving the Track and Gaining an Advantage**

When a competitor leaves the track other than to a designated pit lane during a practice or event, they will re-enter the racing surface at a point as far from the racing line as possible and may not enter at another point on the course that would provide a time or distance advantage. Significant violations may be penalized with a lap penalty (see 3.4.8.4).

#### **3.4.7.4 Unsafe Re-entry**

A competitor who re-enters the course either from a pit lane or from any position off the course may not re-enter in a manner that would potentially cause a collision with karts on the course.

#### **3.4.7.5 Jumping the Start**

The pole-position driver must set a reasonable pace and lead the field to the green flag at a slow, controlled pace. The outside-pole driver cannot start the race ahead of the pole-position driver. All drivers must abide by rule 3.4.2.

#### **3.4.7.6 Ignoring Flags**

Competitors must abide by the directions of the corner workers and officials in charge.

#### **3.4.7.7 Forcing a Driver off the Track**

Competitors must permit other competitors racing room. Deliberate crowding of karts beyond the edge of the track, or any other dangerous change of direction is prohibited.

#### **3.4.7.8 Tire Scrubbing**

On-track "tire scrubbing," maneuvers or direction changes solely to increase heat and/or grip in tires, is not permitted.

#### **3.4.7.9 Driver Contact While Moving**

Driver-to-driver physical contact, including shaking hands, between moving karts is not permitted.

#### **3.4.7.10 Unjustifiable Risk**

Any behavior deemed by the Race Director to represent an unjustifiable risk or reckless endangerment is prohibited.

#### **3.4.7.11 Abandoning Equipment on Track**

Intentionally leaving a kart or other equipment within the area bordered by the track fence during the race day is

prohibited. This includes the track, infield, and grass areas outside the paved borders of the track. Race teams are responsible for the recovery of their karts.

#### **3.4.7.12 Unsportsmanlike Conduct**

Conduct including, but not limited to, abusive and/or foul language, fighting, or refused cooperation will not be tolerated (see 3.2).

### **3.4.8 Penalties**

Penalties are determined by the gravity of the violation and the impact on the fairness of competition, the orderly conduct of the race day, and the interest and integrity of kart racing. Members of the Race Committee shall have the authority to impose any combination of the following penalties against a competitor.

#### **3.4.8.1 Warning**

A competitor may receive a warning to not engage in the conduct in the future. A warning may be delivered on-track by use of the rolled black flag (see 4.19.7).

#### **3.4.8.2 Starting Position Penalty**

A competitor's starting position in the next race event may be adjusted. This is generally used for tech procedure violations such as replacing a marked part.

#### **3.4.8.3 Position Penalty**

A competitor may receive a penalty that adjusts their finishing position. Penalties range from a one (1) or two (2) position penalty to being scored behind another driver. Most infractions result in position penalties.

#### **3.4.8.4 Lap Penalty**

A competitor may have a lap disallowed in the official timing and scoring record. This is generally used for violations of Rule 3.4.7.3.

#### **3.4.8.5 Black Flag**

A competitor may be removed from the course by use of the black flag (see 4.9.15). A competitor who is black flagged is deemed to be disqualified from the race. The "meatball" flag (black with orange disc) is used to remove karts from the course with unsafe equipment and is not a black flag and does not result in disqualification (see 4.19.6).

#### **3.4.8.6 Disqualification**

In extreme cases involving unsportsmanlike conduct, a competitor can be disqualified from the event. A competitor who is disqualified is required to leave the premises and appear before the Badger Kart Club Board of Directors before they may participate in a future Badger Kart Club event (see 3.2.2). A driver disqualified for unsportsmanlike conduct will receive zero (0) points for the day. This zero (0) cannot be used as a droppable race.

#### **3.4.8.7 Technical Disqualification**

Karts and drivers must pass all technical inspections. Karts may be inspected at any time. If a kart or driver fails technical inspection after a race event, the following penalties apply:

- After a heat race: the driver receives 99 points for the heat race.
- After qualifying or pre-final: the driver will start last in the next race.

- After a feature or final: the driver will receive a zero (0) for the day. This zero (0) is generally not droppable, but may be droppable at the discretion of the Head of Tech.
- In the event of an equipment failure, last place points will be awarded to that participant (Meatball Flag).

### **3.4.9 Waived Penalties**

Penalties may be waived if a competitor serves a penalty on track, such as by returning any positions illegally gained, or if a competitor retires for a reason unrelated to the original incident. An official shall provide notice of waived penalties to the involved driver.

### **3.4.10 Restarting engine after start of race**

Competitors may restart their engine after the start of any race. However, no driver shall receive assistance in restarting an engine by another person after the start of any race.

#### **3.4.10.1 Exception**

All Cadet, Sportsman and Kid Karts may receive assistance in restarting their engines after a race has started.

### **3.4.11 No Racing After Checkered Flag**

Racing to the pits or cutoff after the checkered flag is prohibited. Drivers should gradually decelerate and must maintain a controlled pace for their return to the pits. Drivers must remain in finishing order unless the drivers are unsure of their finishing order, or a kart becomes disabled while returning to the pits.

## **3.5 Safety Conduct**

Primary responsibility for the safe condition and operation of a kart and related equipment rests with the driver. Any competitor or participant who does not conduct themselves or their equipment in a safe manner both for themselves or for anyone else can and will be disqualified from an event, required to leave the facility, and can be subject to further disciplinary action.

### **3.5.1 Mandatory Driver Personal Protection**

All mandatory protective clothing must be worn while the kart is in motion. The Race Committee will be responsible for the final decision on the suitability of all "Drivers Personal Protection" equipment. Any additional effort towards safety through extensive personal protective measures will be required as it becomes available.

#### **3.5.1.1 Helmet**

A full-faced helmet with Snell M2015, SA2015, SA2020, or CMR2016, or certain SFI ratings will be the minimum requirement for helmet certifications. BKC will follow WKA's helmet certification policy. Rookie Drivers must place a visible "X" on the back of their helmet. At no time will hair be allowed to be exposed outside a helmet.

#### **3.5.1.2 Protective Clothing**

Full-protection nylon, leather, or suitable substitute driving suit of suitable weight and construction (flame-proof, Nomex, Proban, PBI/ Kevlar, or similar material suits will NOT be accepted as outside driver apparel). Full-protection nylon, leather, or suitable substitute jacket with full-protection full-length pants of suitable weight (warm-up, sweat pants, or windbreakers are not allowed.)

**Full one-piece driving suits, intended for kart racing, are recommended.**

#### **3.5.1.3 Gloves**

Suitable full coverage protective driving gloves (no open backed or altered gloves allowed) are required. Full coverage, gauntlet type gloves, with reinforced palms, knuckles, and finger backs, are recommended.

#### **3.5.1.4 Chest Protectors**

It is mandatory that all drivers 12 and under wear an SFI rated chest protector. **It is HIGHLY RECOMMENDED that all drivers wear chest or rib protectors.**

#### **3.5.1.5 Neck Collars**

Suitable neck collars are required. 360 devices, EVS System and the Leatt Brace are acceptable.

#### **3.5.1.6 Miscellaneous**

Proper driving shoes (high topped with ample ankle support/protection are highly recommended). Sandals or loafers will not be allowed.

#### **3.5.1.7 Other Recommendations**

- Earplugs are highly recommended.
- Chest and rib protector vest such as the Phoenix vest or Rib-Tec for ALL aged drivers. Required for drivers 12 and under (rule 3.5.1.4).
- Mouth guard
- Fire extinguisher in your pit area.
- Rookie drivers should place a visible "X" on the back of their helmet.
- Loose shoelaces should be tucked under tongue of shoe or secured with tape.

### **3.5.2 Smoking or Open Flame**

There will be no smoking or use of any device, which has an open flame, in the pits or in close proximity of any flammable materials or fluids.

## **3.6 Participation and Involvement**

All members are required to participate in the furthering of BKC and its activities, not only as stated herein, but also as implied in both spirit and intent.

All members are required to help with track maintenance, upkeep of the buildings and assist with the running of BKC races or other events, i.e. corner working, weight tech, pre-tech, registration, scoring, etc.

## **3.7 Skill and Conduct**

It will be at the discretion of the Race Committee to refuse participation or require class change and/or starting position, to any competitor based on the Race Committee's interpretation of said competitor's skill and/or conduct.

### **3.7.1 Rookie Number Panels**

Any new participant, either for the first time or for the first time in three years, in practice or in competition, must display a rear yellow number panel with a large black "X". This "rookie" number panel will be in place of a regular rear number panel. The "rookie" yellow number panel **must** be affixed for a period of one competition season.

## **3.8 Officials Policy**

During BKC events, only authorized persons may enter the tower **or talk to an on-track official** during the event.

### **3.8.1 Officials Policy Penalty**

Any unauthorized persons who enter the tower **or talk to or distract an on-track official** during a BKC event can be subject to penalty, such as the Legal Entrant placed to the rear of the field for the upcoming heat/feature (whichever comes first). Any persons entering the tower who are abusive to the officials are subject to immediate expulsion from the grounds and event (see Rule 3.2).

### **3.8.2 Discussions with Officials**

Any Legal Entrant who feels they have discovered a scoring error or wish to discuss an officiating decision for the current day's event, must report this to a race official who is not in the tower or on track. Grid steward, tech official, or registration are suggested. In turn, this official will report to the appropriate official. Legal Entrant may be *invited* to speak to an official for further discussion.

## **4. RACE PROCEDURES AND RULES**

### **4.1 Event Considered Official**

An event is considered "Official" for purposes of awarding race day awards and season championship points, when one or more of the following has occurred:

- An official "Rain Out" has been declared.
- The event has been cancelled for safety reasons.
- All classes that complete the second round of heats or the pre-final will be considered official for the awarding of championship points. Any classes that do not complete the second round of heats or pre-final will be awarded rain points.

### **4.2 Rain Out**

The Race Director may at their own discretion consider any BKC event a "Rain Out" if they feel inclement conditions would preclude a proper day's racing activities. If the event's activities have not been started, the Race Director **must** call a "Rain Out" by 12 pm. (See rule 5.1.3.1 for purchase of Rain Points.)

### **4.3 Legal Entrant**

A legal entrant is that person (and legal guardian where appropriate) who meets in good faith all requirements as set forth in this BKC Rulebook and the current WKA Rulebook, and any and all other requirements made by BKC for reasons of legality and/or safety (see 1.2 Membership Requirements).

To be considered a legal entrant, a competitor (and legal guardian where appropriate) must pay all necessary fees, sign all waivers of liability and affix their assigned race numbers to their karts.

A Legal Entrant may only enter once per class in any BKC event. Only Legal Entrant's may practice on race day.

### **4.4 Pre-Tech Safety Inspection**

All competitors are required to have their racing equipment, including mandatory safety driving gear (helmet, gloves, jacket, neck collar, etc.) pass a pre-race tech safety inspection. (See Kart & Equipment Specifications Rule 7.4).

**NOTE: Passing pre-tech is in no way a guarantee of class legality or technical compliance. Furthermore, this test in no way guarantees ANY rule legality and is intended solely as a safety inspection.**

### **4.5 Sound Test**

Competitors must pass a "Sound Test" to insure their competition in the day's events (see Sound Limitations – Rule 7.1.1).

#### **4.5.1 Practice**

Any BKC official may randomly administer a sound test during any practice session.

#### **4.5.2 Race**

A sound test will be made during the practice or throughout the race day's events. Competitors will be required to pass the sound test at any/all times.

### **4.6 Track Records/Fast Time for the Year**

Track Records or fast time for the year are determined by the fastest time, per competition class, as defined by "Competition Class Requirements" (see Section 6) and are established only during the Feature Race (except Shifters).

#### **4.6.1 Eligibility**

Track Records or fast time for the year can only be awarded to BKC members. Track Records or Fast Time for the year will be recognized at all BKC events that follow the rules and procedures set forth in this BKC Rulebook, i.e., excluding Special Events.

#### **4.6.2 Certification**

Setting a Track Record or fast time for the year will be provisional until the record setter has passed all class requirements and post-race technical inspections.

#### **4.6.3 Standing Track Record**

The prevailing track record will be relinquished if competition class requirements (i.e. tires, restrictors, engines, weight, and/or age) are changed.

### **4.7 Drivers Meeting**

All drivers and a parent of all Sportsman and Kid Kart drivers are required to attend all drivers' meetings, at each event, as scheduled by the Race Director. If a required person fails to make a driver's meeting, the driver will be required to start in the back of both their heat races or the pre-final race.

### **4.8 90-Second Rule**

A 90-second time limit shall apply for all starts where a kart (or karts) is unable to join the class for a race. The 90-second clock will start when the first kart leaves the starting grid. No more karts will be allowed to leave the starting grid after the 90 seconds have passed. The grid marshal shall keep track of the time.

#### **4.8.1 Exception**

Cadet, Sportsman, and Kid Kart drivers may enter after the entire field has taken a green flag at the discretion of the flag person.

### **4.9 Race Details**

#### **4.9.1 Heat Race Format**

##### **4.9.1.1 1<sup>st</sup> Heat**

The first heat will be gridded according to a random draw.

##### **4.9.1.2 2<sup>nd</sup> Heat**

The second heat will be gridded with the inverted draw of the first heat.



**4.9.1.3 3<sup>rd</sup> Heat – Feature**

The Feature line-up will be based on points earned from the first and second heats. The low point driver will start on the pole with the highest point driver at the rear of the field. Finishing position in the Feature race only will determine the championship points that will be awarded to qualified entrants on each MG Tires Championship race day.

**4.9.1.4 Lap counts**

Heat races will consist of 7 laps each.  
 Feature races will consist of 8-10 laps.  
 Changes can be made at the discretion of the Race Director.

**4.9.1.5 Exceptions**

Unfilled track starting position on the grid shall be filled by moving straight up. After applying “90-second rule, Rule 4.8” with karts on track, unfilled positions shall be filled by moving straight up. With the approval of the Race Director, the driver may elect to start in the rear of the field.

**4.9.1.6 Tie**

In case of a tie in total heat race points for a race day, the driver with the better finish in the 2<sup>nd</sup> heat race will receive the higher starting position for the feature.

In the event of a rainout after only two heats, see Rule 5.1.3 for tie breaker.

**4.9.1.7 Rookies**

Any driver new to karting, Kid Kart moving to a new class or an individual who has not raced in 3 years or more, must start in the rear of the field for every race in their first **three events** or the discretion of the Race Director. **The Race Director’s decision is final.**

**4.9.1.9 Heat Race Scoring**

Scoring will be based on the points, listed below, and awarded per finish in each heat race:

Place	Points
1 <sup>st</sup>	½
2 <sup>nd</sup>	2
3 <sup>rd</sup>	3
4 <sup>th</sup>	4
5 <sup>th</sup>	5
6 <sup>th</sup>	6
7 <sup>th</sup>	7
8 <sup>th</sup>	8
9 <sup>th</sup>	9
10 <sup>th</sup>	10
11 <sup>th</sup>	11
12 <sup>th</sup>	12
13 <sup>th</sup>	13
14 <sup>th</sup>	14
15 <sup>th</sup>	15
16 <sup>th</sup>	16
17 <sup>th</sup>	17
18 <sup>th</sup>	18
19 <sup>th</sup>	19
20 <sup>th</sup>	20
and so on	

**DNS will receive last place points in any Heat Races**

**4.9.2 Combined Classes**

On any race day, the Race Director will have the option to run any class with another class. The starting procedure of the joint classes will be determined by the Race Director and that formation will be given to the flag, pit, and scoring personnel.

**4.9.3 Qualifying Race Format**

**4.9.3.1 Qualifying**

During the time set aside for qualifying, karts will be grouped based on number of entrants and allowed a set of three timed laps. The karts are released at intervals determined by the grid steward. Qualifying order is determined by fastest lap in the practice session immediately before qualifying.

Passing is allowed. Any pushing during qualifying will result in those laps being deleted from the scoring of the offending driver.

Track records are determined in Feature race only.

**4.9.3.2 Qualifying Pre-Final Race**

The best time of the three qualifying laps is used to line up the field. Untimed racers line up at the rear of the field in order of random draw. Pre-Final race will be 7 laps. Changes to lap counts can be made at the discretion of the Race Director.

**4.9.3.3 Qualifying Feature Race**

Racers line up according to the Pre-Final race results. Championship points are determined by the feature race results. The Feature race will be 10-12 laps in length. Changes to lap counts can be made at the discretion of the Race Director.

**4.9.4 Ties in Electronic Scoring**

In the event of a tie in electronic scoring, ties will be broken by fastest lap of the race. In the event of identical fast lap times in a race or qualifying, ties will be broken by order the time was set. So, if two people set the same qualifying time, the first person to set the time beats the second.

**4.10 Post-Tech**

After each heat and feature race, each kart and driver must proceed directly to the scale to be checked for minimum class weight and legality (See Section 6). No weight of any kind is to be added to a kart or driver between the finish of competition and weigh-in. Any kart and/or driver leaving without such checks is subject to disqualification for that heat or feature race. No kart may leave the tech area without clearance from the Head of Tech, regardless of finishing position.

**4.10.1 Crewmembers**

Crewmembers are not allowed to cross past the yellow line at the end of the fence while their driver is in the scale line or being reviewed by a Tech Official. Use of cell phones and cameras is not allowed in the tech area by anyone other than race officials.

**4.11 Designated Driving Areas**

There will be no driving of karts on any area except on paved areas designated for races.

#### **4.12 Expert Class Option**

The Race Director may, as an option, allow any participant not meeting BKC rules as to class structure, etc., to run in the Expert Class.

#### **4.13 Loss of Exhaust System**

If a driver loses their muffler or exhaust system, or if it becomes inoperable after the start of a race, they will automatically be given a mechanical black flag.  
(See Exceptions – Rule 1.3.1.2).

#### **4.14 Finish Restrictions**

No kart shall be pushed, pulled, or otherwise propelled to the finish line other than by means of its own power or momentum.

#### **4.15 Replacement/Change/Alteration/Switching Restrictions**

##### **4.15.1 Driver Restrictions**

There will be no switching of a driver in any BKC race in the same class during an event.

##### **4.15.2 Equipment Restrictions**

###### **4.15.2.1 Kart**

There will be no switching of kart (chassis) in any BKC race in the same class during an event.

###### **4.15.2.1.1 Accident Caused Chassis Switching**

If, during a heat race, a competitor's chassis is damaged, they shall report this damage to the Race Director. The Head of Tech may then allow the competitor to install the motor and exhaust system on a different chassis and start at their gained position (See Exception – Rule 4.16.2).

###### **4.15.2.2 Engine**

Any changes or alterations of engines or engine components marked by the tech personnel must first be approved by the Technical Director. Both the original and replaced/alterated engine and component will be considered marked and subject to tech. This includes broken components. After the changes or alterations have taken place, the kart must then start in the rear for the next race of that day.

**The only exceptions will be non-tech items.**

###### **4.15.2.3 Other components**

Tech personnel may mark any other components, (i.e., tires, exhaust systems, seats and mountings, etc.). Once marked, that component may not be changed or altered during the event without prior approval of the Technical Director.

#### **4.16 Accident Requirements**

##### **4.16.1 Inspection**

Karts involved in accidents may be required to stop for inspection by officials.

##### **4.16.2 Red Flag**

If at any time an incident causes a red flag or a kart overturns (flips), the red flag will be displayed promptly. If the race is half completed, the finish will revert to the last lap scored and the kart(s) involved in the incident which caused the red flag, shall

be scored in last place. If the race is less than halfway through, there will be a restart, reverting to the last lap scored, with the kart(s) involved in the red flag incident being moved to the rear of the pack. Restarts after one lap has been completed will be single file.

A kart that has been involved in a red flag incident cannot continue to race until it has been checked by a tech official.

#### **4.17 Loss of Brakes**

If a kart's braking ability is lost, it will be the driver's obligation to safely pull clear of the track and discontinue racing. Do not enter the pits unless speed is minimal and a safe stop can be accomplished. Any competitor's failure to comply with this rule will be subject to immediate disqualification.

#### **4.18 Fuel/Oil and Other Fluids**

##### **4.18.1 Spills**

Any competitor knowingly spilling oil or fuel on the track or in the pits will be subject to suspension for the entire event.

##### **4.18.2 Fluids or Waste Material Collection and Disposal**

The user must dispose of tires or waste materials. It is the user's responsibility to dispose of all items in compliance with all or any Federal, State, or Local laws while on Wolf Pacing Raceway property. Anyone not complying with this policy cannot use Mill-Rite Raceway for six (6) months from the date of infraction.

#### **4.19 Flags Displayed by the Flag Person**

Each BKC competitor is responsible for the knowledge of and adherence to the following flag signals.

##### **4.19.1 Green Flag**

This indicates the start of competition, or practice, and will be kept visible at all times while the track is clear for racing.

##### **4.19.2 Yellow Flag**

Displayed at the start/finish line and/or by corner workers. There are three levels of yellow flag conditions. A "furlled and pointed" flag will point to an oncoming, off track, but possibly treacherous condition; passing is still allowed.

A "stationary" yellow, indicates there may be karts or debris in the next corner or upcoming straightaway, or a kart immediately off the track in a corner. The track may be partially blocked. No passing is allowed until after the reason for the yellow flag has been passed.

A yellow flag, "waving" in a figure eight pattern, indicates a serious problem on the track ahead, such as karts or debris in the racing line. No passing is allowed until after the reason for the yellow flag has been passed. There is no full course yellow flag condition during a race.

##### **4.19.3 Red Flag**

Displayed at start/finish line only (and/or red light condition on track lights). The red flag indicates there is a hazardous or unsafe condition on the track. All scoring is stopped and will revert to the last completed lap. Proceed slowly to the start/finish line and come to a complete stop.

##### **4.19.4 White Flag**

Indicates one lap to go. The checkered flag will be displayed at the completion of the white flag lap regardless of lap count.

##### **4.19.5 Black Flag Waving**

Requires the competitor to refrain from further competition, proceed directly to the scale at a reduced speed and to stop at the scale. Competitor will be informed of the driving infraction and of the action taken or pending by the officials (i.e., disqualification, position penalty, etc.).

##### **4.19.6 Black Flag with Orange Disc (Meatball Flag)**

Displayed in practice and races for safety or mechanical infractions (neck collars, mufflers, etc.). Requires the competitor to refrain from further competition, proceed directly to the scale at a reduced speed, and to stop at the scale. Competitor will be informed of the infraction. This is not a disqualification.

##### **4.19.7 Rolled Black Flag**

Is a warning that the competitor's driving technique is bordering on disqualification and that any further display of the same will be cause for immediate disqualification.

##### **4.19.8 Blue Flag with Yellow Sash**

Indicates another competitor is rightfully attempting to put you a lap down. When displayed, competitor should maintain a consistent racing line, allowing faster karts to pass.

##### **4.19.9 Checkered Flag**

Displayed at the finish of competition or practice.

#### **4.19.10 Black and Checkered Flags**

Used to end the event under conditions subject to review and subsequent action by the officials (i.e., pending disqualification, position penalties, further discussion, etc.).

## **5. BKC MG TIRES CHAMPIONSHIP POINTS SERIES**

There shall be a BKC Season Championship Points Series in each competition class except “Kids Karts” and “Expert”. The races that shall make up this championship point series will be determined and made known to the BKC general membership one month prior to the beginning of the first race.

Finishing position in each class for the BKC MG Tires Championship Points Series will be determined by accumulating awarded points from each scheduled race, including rainouts (see schedule).

### **5.1 Eligibility**

Only BKC members, in good standing, will be eligible for the BKC Championship Points Series. Drivers must enter a minimum of 6 races to qualify for awards.

#### **5.1.1 Legal Entrant**

To receive championship points for a non-workday race event, a competitor must be the “Legal Entrant” in that class (see Rule 1.2 & 4.3).

#### **5.1.2 Attendance**

To receive championship points for a non-workday race event, a competitor must take a green flag during one of the heat races, or the feature race, and verifiably pass minimum class weight requirements and technical inspection after that race. Failure to scale or take post-race tech will result in a DQ for the day.

Competitors taking the green flag in at least one heat race, but do not start or finish the feature race, will be awarded last place points in the following order: DNF (Did Not Finish) will be awarded last place points. In cases of more than one DNF, points order will be based on the position held prior to the incident or failure. DNS (Did Not Start) will be awarded last place points behind any DNF's. In the case of more than one DNS, points order will be based on assigned grid position.

#### **5.1.3 Rain Outs**

If a competitor is entered in a competition class that does not complete both heat races or pre-final, the competitor will be awarded **200** rain points.

##### **5.1.3.1 Tie Breaker for Rainout after two heats**

In the event of a tie and rainout after the two heat races, the points for final will be determined by the fastest lap time from the heat races. Qualifying format points based on lineup for final.

##### **5.1.3.2 Purchase of Rain Points**

In the event of a possible rain-out, competitors may purchase rain points until 10:30 a.m. on raceday. They may be purchased in person, via telephone, or using the online registration system. Telephone and online purchases must be made with a credit card. All points must be paid for prior to 10:30 a.m., no exceptions. If it is later determined that conditions have improved such as to allow racing, no refunds will be issued. The cost for rain points will be the same as the normal race entry fee.

## **5.2 Championship Points Details**

All scheduled point races count for the BKC MG Tires Championship Points Series based on the following, plus number of entries per competition class, per race event.

1 <sup>st</sup> place	200 pts
2 <sup>nd</sup> place	175 pts
3 <sup>rd</sup> place	155 pts
4 <sup>th</sup> place	140 pts
5 <sup>th</sup> place	130 pts
6 <sup>th</sup> place	120 pts
7 <sup>th</sup> place	110 pts
8 <sup>th</sup> place	100 pts
9 <sup>th</sup> place	90 pts
10 <sup>th</sup> place	80 pts
11 <sup>th</sup> place	75 pts
12 <sup>th</sup> place	70 pts
13 <sup>th</sup> place	65 pts
14 <sup>th</sup> place	60 pts
15 <sup>th</sup> place	55 pts
16 <sup>th</sup> place	50 pts

17 <sup>th</sup> place	45 pts
18 <sup>th</sup> place	40 pts
19 <sup>th</sup> place	35 pts
20 <sup>th</sup> place	30 pts
21 <sup>st</sup> place	25 pts
22 <sup>nd</sup> place	20 pts
23 <sup>rd</sup> place	17 pts
24 <sup>th</sup> place	14 pts
25 <sup>th</sup> place	11 pts
26 <sup>th</sup> place	8 pts
27 <sup>th</sup> place	5 pts
28 <sup>th</sup> place	2 pts
29 <sup>th</sup> place	1 pts
30 <sup>th</sup> place	1 pts
DQ	0 pts

### **5.2.1 Tie**

In case of a tie, the competitor who has a better record of the tiebreaker criteria below shall be awarded the better position. Once either of the tied competitors achieves a better record at any of the criteria below (in order), the tie will be considered broken and the competitor with the better record shall be awarded the better position:

- Most wins throughout the Championship season.
- Most 2<sup>nd</sup> place finishes throughout the season.
- Most 3<sup>rd</sup> place finishes throughout the season.

### **5.2.2 Point Standings**

For 2023, your best **12 out of 14** BKC MG Tires Championship Points Series events will be counted towards the BKC MG Tires Championship Points Series.

#### **5.2.2.1 Event Disqualifications**

In the event a driver is disqualified for unsportsmanlike conduct, the driver will receive zero (0) points for the day and may not use the race as a “drop race.” (see rule 4.9.1.8 Disqualifications)

#### **5.2.2.2 Championship Points Protests**

Discrepancies in championship points cannot be contested after 2 weeks from the time of posting on the BKC Website. There will be no exceptions.

## **5.3 Year-End Awards**

Awards will be given in classes that end the season with a minimum of three eligible drivers (see Rule 5.1). In classes with three or more eligible drivers, awards will be issued as follows:

- Kid Karts – All drivers will receive an award.
- Sportsman Classes – All drivers will receive an award.
- Junior Classes – Top five (5) points finishers receive awards.
- Senior Classes – Top five (5) points finishers receive awards.

## **6. COMPETITION CLASS REQUIREMENTS**

### **6.1 Briggs 206 Cadet**

#### **6.1.1 Age**

7 through 10 years old  
Past year champion must move out of class (see 1.7.2.4)

#### **6.1.2 Engines/Fuel/Weight**

Briggs & Stratton 206 (restricted)  
Gas only  
240 lbs. (kart and driver) Standard & Cadet Kart

#### **6.1.3 Tire Spec**

MG RL1 or VK (Orange) 10x4.60-5 front and rear

#### **6.1.4 Miscellaneous**

Briggs & Stratton 206 (restricted) requires unaltered "Red" .440-inch slide (P/N 555733) and locking cap. Engine and clutch tech per the Briggs & Stratton 206 United States Rule Set. Drum clutch required.

### **6.2 Briggs 206 Sportsman**

#### **6.2.1 Age**

8 through 12 years old

#### **6.2.2 Engines/Fuel/Weight**

Briggs & Stratton 206 (restricted)  
Gas only  
260 lbs. (kart and driver) Standard & Cadet Kart

#### **6.2.3 Tire Spec**

MG RL1 or VK (Orange) 10x4.60-5 front and rear

#### **6.2.4 Miscellaneous**

Briggs & Stratton 206 (restricted) requires unaltered "Green" .490-inch slide (P/N 555740) and locking cap. Engine and clutch tech per the Briggs & Stratton 206 United States Rule Set. Drum clutch required.

### **6.3 Mini Swift**

#### **6.3.1 Age**

7 through 12 years old

#### **6.3.2 Engines/Fuel/Weight**

IAME Mini Swift  
250 lbs. (kart and driver) Standard & Cadet Kart

#### **6.3.3 Bodywork**

Front nose must be equipped with a CIK-homologated pushback nose system with a maximum of two CIK-homologated clamps.

#### **6.3.4 Tire Spec**

MG SH, HZ, or HZi (Red) 10x4.60-5 Front and rear.

#### **6.3.5 Miscellaneous**

Engine per current WKA tech.

### **6.4 Briggs 206 Junior**

#### **6.4.1 Age**

12 through 15 years old

#### **6.4.2 Engines/Fuel/Weight**

Briggs & Stratton 206 (restricted)  
Gas only  
320 lbs. (kart and driver)

#### **6.4.3 Tire Spec**

MG RL1 or VK (Orange) 10x4.60-5 front 11x6.00-5 rear

#### **6.4.4 Miscellaneous**

Briggs & Stratton 206 (restricted) requires unaltered "Yellow" .570-inch slide (P/N 555741) and locking cap. Engine and clutch tech per the Briggs & Stratton 206 United States Rule Set. Drum clutch required.

### **6.5 IAME 100 Junior**

#### **6.5.1 Age**

12 through 15 years old

#### **6.5.2 Engines/Fuel/Weight**

KA100 with Junior Restrictor  
Gas and Oil only  
320 lbs. (kart and driver)

#### **6.5.3 Bodywork**

Front nose must be equipped with a CIK-homologated pushback nose system with a maximum of two CIK-homologated clamps.

#### **6.5.4 Tire Spec**

MG SH, HZ, or HZi (Red) 10x4.60-5 front, 11x7.10-5 rear.

#### **6.5.5 Miscellaneous**

KA100 engine, Tillotson HW-33A carburetor, factory airbox required. Exhaust as supplied by manufacturer. Junior restrictor as supplied by manufacturer.

### **6.6 Briggs 206 Senior Medium**

#### **6.6.1 Age**

15 years or older

#### **6.6.2 Engines/Fuel/Weight**

Briggs & Stratton 206  
Gas only  
360 lbs. (kart and driver)

#### **6.6.3 Tire Spec**

MG RL1 or VK (Orange) 10x4.60-5 front 11x6.00-5 rear

#### **6.6.3 Miscellaneous**

Engine and clutch tech as per current Briggs & Stratton 206 Senior specifications in the Briggs & Stratton 206 United States Rule Set. Drum clutch required.



## **6.7 Briggs 206 Senior Heavy**

### **6.7.1 Age**

15 years or older

### **6.7.2 Engines/Fuel/Weight**

Briggs & Stratton 206

Gas only

390 lbs. (kart and driver)

### **6.7.3 Tire Spec**

MG RL1 or VK (Orange) 10x4.60-5 front 11x6.00-5 rear

### **6.7.3 Miscellaneous**

Engine and clutch tech as per current Briggs & Stratton 206 Senior specifications in the Briggs & Stratton 206 United States Rule Set. Drum clutch required.

## **6.8 Yamaha Senior**

### **6.8.1 Age**

14 years or older

### **6.8.2 Engines/Fuel/Weight**

100cc Yamaha KT100S

Gas and Oil

355 lbs. (kart and driver)

### **6.8.3 Bodywork**

Front nose must be equipped with a CIK-homologated pushback nose system with a maximum of two CIK-homologated clamps.

### **6.8.4 Tire Spec**

MG SH, HZ, or HZi (Red) 10x4.60-5 front 11x7.10-5 rear

### **6.8.5 Miscellaneous**

100cc Stock Yamaha KT100S. Must use original unaltered RLV SR-Y pipe with unaltered #9110 header. Engine per current WKA tech.

## **6.9 TaG 100 Senior**

### **6.9.1 Age**

15 years or older

### **6.9.2 Engines/Fuel/Weight**

KA100

Vortek ROK VLR

Gas and Oil only

360 lbs. (kart and driver)

### **6.9.3 Bodywork**

Front nose must be equipped with a CIK-homologated pushback nose system with a maximum of two CIK-homologated clamps.

### **6.9.4 Tire Spec**

MG SH, HZ, or HZi (Red) 10x4.60-5 front, 11x7.10-5 rear.

### **6.9.5 Miscellaneous**

KA100 engine, Tillotson HW-33A carburetor. ROK VLR with Tillotson HW-38A carburetor. Factory airbox required. Exhaust as supplied by manufacturer.

## **6.11 Expert**

### **6.11.1 Age**

Any individual who is at least 8 years old may enter the Expert class. Drivers 8 – 15 years old may race this class only with the Race Committee's approval.

**Note: The intention here is to provide a place to race for any visitors to our track whose kart or equipment do not fall into any of BKC's class structures.**

### **6.11.2 Requirements**

Kart must pass safety pre-tech.

Kart/driver combination must satisfy the requirements of a nationally recognized kart sanctioning body.

#### **6.11.2.1 Fuel**

Open fuel. No Dioxane. Subject to test for such.

## **7. COMPETITION EQUIPMENT REQUIREMENTS**

**NOTE:** Specifications listed herein apply to all classes and equipment except those specifications that are specifically associated (and listed) with the Kid Kart class.

**NOTE:** "WKA kart and engine rules shall apply unless otherwise specified herein" (**See Rule 1.1.**). WKA's rules and regulations pertaining to competition equipment, including engine tech, can be found in great detail in the most current WKA Tech Manual.

*The rules, regulations, procedures, and/or specifications, specified herein, only supersede, supplement, clarify, or add emphasis to those applicable WKA rules, and do not constitute the complete set of rules pertaining to competition equipment used at BKC events.*

### **7.1 General Requirements**

#### **7.1.1 Sound Limitations**

The sound limit shall not exceed 95 dBa.

##### **7.1.1.1 Mufflers Mandatory**

All motors must run mufflers at all times. (See Muffler Requirements under Kart Specifications – Rule 7.2.6.).

### **7.2 Engine and Engine Equipment Requirements**

#### **7.2.1 Claiming**

No claiming of engines in any class.

#### **7.2.2 Engine Tech**

Any engine is subject to tech inspection **at any time**. Any technical inspection of an engine must take place the same day as the event. Refusal or non-cooperation of any tech inspection subjects the entrant to disqualification and suspension from participating in the next two (2) BKC events.

#### **7.2.3 Engine Legality**

Engine legality shall be determined according to the specifications contained in the current WKA Tech Manual, with exceptions as otherwise noted in this 2023 BKC Rule Book.

##### **7.2.3.1 Yamaha Heads**

All heads must include the Yamaha name in the casting and may be compared to known stock.

##### **7.2.3.2 Yamaha Cylinders**

All cylinders must have a "787" embossed on one side and either an "Y3" or "Y4" embossed on the side.

#### **7.2.4 "Stock" Defined**

All motors in all classes must be run as "Stock" (i.e., unmodified), as per current WKA technical rules, unless specifically noted herein.

### **7.2.6 Muffler Requirements**

#### **7.2.6.1 2-Cycle Requirements**

All 2-Cycle racing participants will be required to use exhaust systems that meet current WKA tech specifications.

The expansion chamber must outlet into the rearwards half of the silencing can (i.e., that portion furthest from the header pipe).

There may be no physical connection between the expansion outlet and the exhaust gas outlet hole to atmosphere.

SSX box muffler must be original unaltered RLV-SSX part #7548 or EXT6015 (the can with four outlet holes spaced 90 degrees to each other), part #7543 (the can with the four outlet holes evenly spaced between the 12 and 3 o'clock positions) or part # 7540 (four holes up).

#### **7.2.6.2 4-Cycle Requirements**

Muffler required. Muffler must exhaust to atmosphere a minimum of one inch past the gas tank. All 4-Cycle motors must use the RLV-B91 Exhaust Silencer at all times.

The RLV-B91 MO (square holes) model exhaust silencer would be legal in Expert class only.

### **7.2.7 Restrictors Defined**

May be in the form of a plate, manifold or carburetor slide length. See Section 6 (Competition Class Requirements) for specifics.

All restrictors must meet current WKA specifications in addition to BKC requirements.

Installing the restrictor in such a way as to defeat the function of the restrictor is illegal.

### **7.2.8 Clutches**

Axle clutches allowed ONLY in the Expert class. Wet type clutches must be sealed to prevent leaks.

### **7.2.9 Clutch Guard**

All 2-Cycle karts with outboard mounted clutches must have a third-bearing support or some other clutch guard to contain the clutch in case the crankshaft should break. Clutches mounted between engine and seat do not require a third-bearing support or guard.

### **7.2.10 Carburetor**

#### **7.2.10.1 Remote Carb Adjusters**

Suitable remote carburetor mixture devices will be allowed, subject to safety considerations.

#### **7.2.10.2 Carburetor Supports**

Carburetor supports are allowed, subject to approval.

## **7.3 Fuel and Fuel System**

### **7.3.1 Fuel System Security**

All fuel lines must be safety wrapped, clamped, or otherwise suitably secured, at all connections.

No pressurized fuel tank(s) allowed.

All flip type fuel caps shall be safety fastened during an event.

### **7.3.2 4-Cycle Fuel**

LO206 classes are required to run gasoline only.

### **7.3.3 4-Cycle Fuel Test Procedure**

#### **7.3.3.1 Gasoline**

BP 87-octane regular gasoline, purchased on the day of the race from the BP (Bull Frog) station at 319 N Main St Dousman, WI. Test range plus or minus 10 on the Digitron fuel meter to tech sample.

#### **7.3.3.3 Additional Fuel Test**

It shall be the Tech Official's decision as to which system is used and/or any additional fuel checks. Additional checks may include fuel sampling, hydrometer, water test, chemical or electronic evaluation of fuel.

### **7.3.4 2-Cycle Fuel Test Procedure**

#### **7.3.4.1 Gas and Oil**

6-8 oz. oil per gallon of BP 93-octane premium gasoline purchased on the day of the race from the BP (Bull Frog) station at 319 N Main St Dousman, WI.

Oil may be any of the following:

- Redline Racing Oil
- Xeramic Castor Evolution 2T Kart Racing Oil
- ELF HTX-909

Test range plus or minus 10, on the Digitron fuel meter, to tech sample. All 2-Cycle competitors will purchase fuel from the spec station and mix the fuel to the above regulations.

#### **7.3.4.2 Dioxane Reagent Test**

Secondary test to be announced.

#### **7.3.5 Fuel Test Protest**

Any competitor can protest another competitor's fuel in their class. The protested fuel will be checked immediately by Rule 7.3.3. or 7.3.4 as a preliminary test. Secondary test to be announced.

A \$300.00 fee must accompany all **fuel** protests, to be refunded only if the protest is upheld.

## **7.4 Kart and Equipment Requirements**

The eligibility of all karts to compete shall be determined by their meeting the requirements as set forth in this section. The responsibility of meeting these specifications rests with the Legal Entrant.

**NOTE:** A Pre-Race Technical Safety Inspection (pre-tech) approval shall not guarantee legality at any post competition inspection.

### **7.4.1 Required Equipment Specifications**

#### **7.4.1.1 Overall Height**

Maximum is 26.0", includes steering fairing.

#### **7.4.1.2 Overall Kart Width**

Maximum overall width, including bodywork is 55 1/8". The rear tire may be inside the bodywork. Pod, panel, or nerf bar can be a maximum of one inch per side wider than the rear wheel/tire.

#### **7.4.1.3 Overall Length**

Standard Kart maximum 82.0"

Cadet Kart maximum 71.0"

#### **7.4.1.4 Tread Width**

Minimum is 28.0", measured from the centerline of the right rear tire to the centerline of the left rear tire.

#### **7.4.1.5 Wheelbase**

Standard Kart maximum 43.0", minimum 39 3/4"

Cadet Kart maximum 41", minimum 35"

## **7.4.2 Bodywork**

### **7.4.2.1 Bodywork**

All bodywork must be neat in appearance and in good repair. Bodywork that appears loose and in danger of falling off may be subject to a mechanical black flag. A kart that loses bodywork during a race will be subject to a mechanical black flag and will receive last-place points. Mounting must be secure and of good workmanship.

**All bodywork must be CIK style.** All 2-Cycle and 4-Cycle classes must run bodywork that is CIK in appearance and legal to "Manufacturers Cup" rules as set forth in the current WKA Tech Manual (**See Rule 7.4.2.2. Nose Cones and Rule 7.4.2.4. Steering Fairings, for exceptions to WKA rules**).

e.

### **7.4.2.2 Nose Cones**

#### **7.4.2.2.1 CIK-Style Nose Cones**

CIK nose cones are legal in all classes. Quick-attaching systems for mounting of nose cones are optional. Solid butterfly clamps or bolting upper hoop of bumper to bottom of bumper/frame to secure nose cone is allowed. Nose cones must be intact as per specifications throughout race event. CIK nose cones are subject to pre-tech and post-tech.

Last place points will be awarded if nose cone falls off during heat or feature race.

#### **7.4.2.2.2 CIK-Style Push-Back Nose Cones**

In classes where CIK-style push-back nose cones are required, push-back nose cones must remain in the correct position during all times of competition.

If any part of the top or bottom bar/bumper is in the drop-down area as pictured below, the competitor will be assessed a 1-position penalty per side, with a maximum penalty of 2 positions. If a penalty for avoidable contact or rough driving is also assessed, only the greater position penalty applies. This penalty may be waived if, at the Race Director's discretion, the contact that dislodged the bumper was unavoidable, such as a

collision with a stationary object. A collision with a kart racing in traffic is not unavoidable.

Any competitor who attempts to reset their nose cone to the correct position either on-track or before crossing the scale will be disqualified for that race (see rule 4.9.1.8.2).

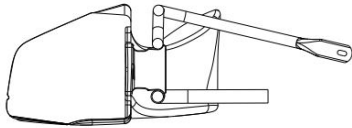

Correct Position

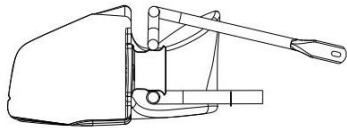

Acceptable Position

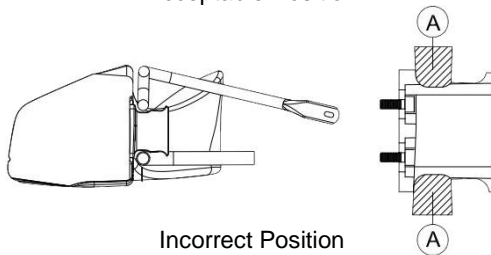

Incorrect Position

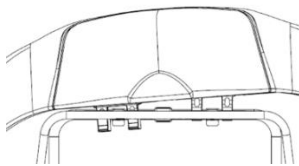

Incorrect Position

#### **7.4.2.3 Side Panels**

CIK-style bodywork requires CIK-style side pods, and surface must be uniform and smooth. CIK-style pods must be securely mounted.

#### **7.4.2.4 Steering Fairing**

Steering fairing must be mounted with easily bendable tabs or struts. The fairing and/or mounting materials must expose no sharp edges to the driver. Fairing must be at least 1 15/16" away from the steering wheel.

CIK-style fairing minimum width is 9 7/8-inches and a maximum width 11 13/16-inches (both chord measurements) and must not be above the horizontal plane through the top of the steering wheel.

All Sportsman classes may run a steering fairing provided they meet all other WKA size and clearance rules.

#### **7.4.2.5 Rear Bumpers**

Full-width bumpers are required in all classes. Bumpers must have a minimum length of half the width of the corresponding rear tire and may not exceed the width of the corresponding rear tire by more than 1 inch.

#### **7.4.3 Spindle Nuts**

Front spindle nuts must be cotter-keyed, safety-wired, or pinned. Spring Clips or E-type safety fasteners are allowed in place of safety wire or cotter pins where applicable. The use of castle-type nuts is suggested.

#### **7.4.4 Ballast/Weight**

All weight added to meet minimum kart/driver weight requirements should be bolted to the kart. Carrying of the ballast on the driver's person is prohibited.

Ballast weight in all karts must be securely bolted to the kart with a minimum of 5/16 inch Grade 5 or better through-bolt. If a single weight or combined weights are greater than 7 pounds, 2 (two) 5/16-inch bolts must be used. All ballast securing bolts must be safety wired, cotter keyed, or double-nutted.

Any lead shot or loose material used as ballast must be mechanically sealed by use of a bolting device. Tape, hose clamps, tie wraps, or fasteners other than bolts are not legal for attaching ballast weights to competition karts. Tech inspectors will make thorough inspections of weight installation to confirm that they meet the bolt-in requirement.

No weight shall be bolted to the underside, nerf bars, or bumpers of the kart; weights may be mounted on front bumper if solid/non-CIK nose cone is used.

Where weight is attached directly to the seat of a competition kart, adequate reinforcement must be used to ensure weights will remain properly attached at all times. Large diameter fender washers or sheet metal reinforcement at the attachment location is required.

All ballast/weight must be painted bright white for safety reasons and must have the kart number written or painted on the weight in a contrasting color.

#### **7.4.5 Brakes**

All karts shall have a brake operating in such a manner as to brake both rear wheels equally and adequately. Any deviation requires specific BKC Board approval.

##### **7.4.5.1 Wolf plates**

It is STRONGLY recommended that karts where the rear brake calipers are NOT between the seat and the rotor utilize a "wolf plate" system to prevent driver injury from the brake rotor in the case of a strong rear impact or broken seat. Metallic plates attached to the back of the seat can be used instead of an actual Wolf Plate.

#### **7.4.6 Chain Guard**

Karts shall be equipped with a chain, belt, or gear guard implemented to eliminate any possibility of injury. The chain guard shall include covering the rear sprocket.

#### **7.4.7 Chain Oiler**

The use of any type of chain oiler is **not** permitted.

#### **7.4.8 Driver's Compartment**

All parts of the driver are to be limited to the confines of the width and length of the kart. If a driver's feet extend beyond the leading edge of the front tires, then adequate bumper protection shall be incorporated within the overall maximum length. A driver's feet shall not extend beyond the bumper when the pedals are fully depressed.

#### **7.4.9 Unwanted Projections**

No projection from the vehicle, which constitutes a hazard to other vehicles or drivers, will be permitted (See Rule 7.4.1.2.).

##### **7.4.9.1 Rear Bumper Bolts**

Rear bumper bolts that protrude out past the fastening nut or device must be covered. This can include, but is not limited to, acorn nuts or duct tape.

#### **7.4.10 Gearbox**

No transmission, gearbox, or other device which permits a change of gears or sprocket ratios while the vehicle is in motion is permitted, except as specifically allowed in the Shifter class (See Rule 6.16.).

#### **7.4.11 Number Identification**

Number identification will be any solid-colored background panels with visibly contrasting numbers on all four sides of the kart.

**Up to three-digit numbers only, no letters. No duplicate numbers per competition class.** Numbers must be a minimum of **five** inches high.

Note: Inability of Race Officials to read the numbers may result in a mechanical DQ for that race.

##### **7.4.11.1 Exception - Rookies**

Participants classified as “rookies” to BKC must run a yellow rear number panel with a black “X” (see Rule 3.7.1).

#### **7.4.12 Seat and Floor Plan**

No void, large enough for any part of the driver’s body to inadvertently pass through shall be permitted.

#### **7.4.13 Seat Belts**

The use of seat belts is prohibited.

#### **7.4.14 Seat Struts**

The point where the seat strut attaches to the seat should be adequately reinforced or protected to prevent the strut from piercing the seat, causing driver injury on impact.

#### **7.4.15 Exposed Sprockets**

Axle sprockets not fitted with a drive chain are prohibited.

#### **7.4.16 Steering**

Steering shall be such that the pitman arm cannot rotate over center.

All steering system bolts shall be of aircraft standard quality (Grade 5 or better) and shall be 5/16-inch minimum diameter. Steering wheel attachment must be secured with aircraft quality nut(s), 6mm minimum.

All steering assembly bolts and nuts, including spindles and kingpins, shall be safety wired, cotter keyed or e-clipped.

All collars and other devices used to retain the steering column in upper and lower guides shall be secured to prevent possible loss of collar.

All rod ends shall have universal type swivel joints and jam nuts.

Welding of steering wheel to hub or hub to shaft is prohibited.

#### **7.4.17 Throttle**

Karts shall be equipped with a throttle incorporating a return spring, which closes the throttle when the pedal is released. It is recommended that a secondary return spring be installed. Any deviation requires specific BKC Board approval.

#### **7.4.18 Monitoring Devices/Radios**

All audio devices used by drivers are prohibited while on the track. These include 2-Way Radios, cellular phones, Bluetooth helmets, iPod, MP3, and other music devices.

### **7.5 Tires**

#### **7.5.1 Requirements**

Participants in all classes are required to use ONLY MG Tires during any MG Tires BKC Championship Points Series race.

#### **7.5.2 Tire Specification**

See Section 6 “Competition Class Requirements” for individual class tire compound and size requirements.

#### **7.5.3 Rain Tires**

Rain tire practice will be allowed at BKC at the discretion of BKC officials. There must be a board member or official present (includes Caretaker) for rain tire practice to be allowed. Each participant must receive specific approval.

#### **7.5.4 Tire Treating Prohibited**

Only untreated tires are allowed. No altering of any kind is allowed. Wire brushing or scraping to remove debris or rubber build up is allowed.

##### **7.5.4.1 Penalty**

The penalty for violating the tire-treatment ban will be a suspension for 30 days or the next two BKC points races, whichever is greater. Suspension days will include non-race days. Suspension days cannot be used as drop races.

#### **7.5.5 Tire Testing**

Tire testing may include, but is not limited to, comparing durometer readings, visual inspection, sniffer testing, painting inside, or lab testing.

### **7.6 Transponders**

#### **7.6.1 Usage**

All classes except Kid Karts are required to use MyLaps compatible transponders, such as the AMB TranX160 or MyLaps X2 or subsequent versions, to be scored and receive championship points. Transponders are mandatory for all race-day sessions, including practice.

##### **7.6.1 Mounting**

Transponders must be mounted on the left side of the kart at a minimum distance of 9 inches back from the back side of the spindle bolt head.



## Transponder Location

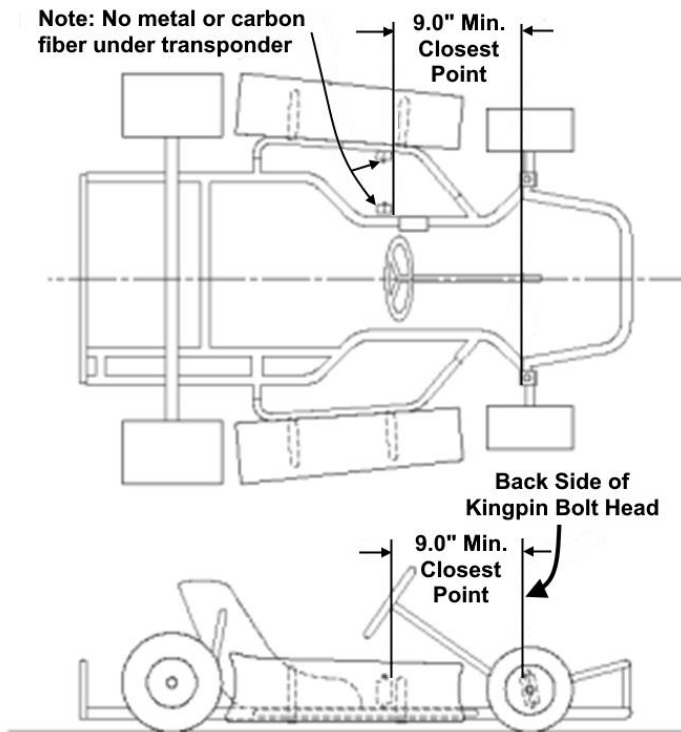

### 7.7.3.2 Briggs Junior 206

Per 2023 WKA Specifications

Minimum weight 175 lbs. (kart and driver)

Must follow BKC Spec Fuel Rule 7.3.3.1 Gasoline

Gear Ratio: 17/57: 17-tooth clutch driver with a 57-tooth rear sprocket. #35 chain

### 7.7.3.3 Honda GXH50U

As supplied by Honda Performance development.

Minimum weight 150 lbs. (kart and driver)

Engine seal: As installed by HPD. If seal damaged or disturbed in any way the entrant will be disqualified.

Must follow BKC Spec Fuel Rule 7.3.3.1 Gasoline

Carburetor: KEIHIN BF32E

- Throttle plate: # 140 as manufactured with sharp edges. Must retain stock screw.
- Emulsion tube: Minimum length 1.140"
  1. Through hole: .055" No-go
  2. Two holes at bottom, 180° apart .028" No-go
  3. Eight holes above bottom band 90° apart .020" No-go
  4. Four holes at top 90° apart .020" No-go
- Float: F3
- Main Jet: maximum .020" No go
- Maximum venturi size (no-go): 15mm

The only allowed changes to the carburetor are main jet changes. Any other change or modification is not permitted.

### 7.7.3.4 IAME Bambino

Minimum weight 160 lbs. (kart and driver)

Gear Ratio: 10/89: 10-tooth driver with an 89-tooth rear sprocket. #219 chain.

Must follow BKC 2-cycle Fuel Rule (7.3.4.1 Gas and Oil).

IAME Bambino engine as manufactured. Tillotson HS-325A carburetor as manufactured. Fuel filter permitted between tank and carburetor. OEM air filter cover to be used as manufactured.

Spark Plug: NGK BR8EG, BR8EIX, BR9EG, BR9EIX, BR10EG, or BR10EIX with OEM washer or cylinder-head temperature sensor in place. Spark plug boot may be OEM or NGK.

OEM muffler as manufactured. Exhaust gas temperature sensors are illegal.

Clutch as supplied by manufacturer. Maximum drum ID 3.354" (85.2mm). Must be IAME 10-tooth drum without holes. Clutch oiling is illegal.

Clutch test: while on kart stand with brake held and throttle applied engine RPM must not exceed 5000.

### 7.7.4 Kid Kart Race Format

Kid Karts will have three races of 7 laps each race day. Grid positions will be determined by the Kid Kart Coordinator, with consideration given to experience and speed. It is suggested that Kid Karters of similar experience and speed be gridded by random draw. Changes to this format can be made at the discretion of the Race Director.

## 7.7 Kid Karts

### 7.7.1 Age

5 through 8 years old. Must be 5 years old to practice or race. If an existing Kid Kart racer turns 8 during the season, they have the option of remaining in Kid Karts for the remainder of the season or moving up to a Sportsman class.

### 7.7.2 Kart Specifications

Front Width: 40-inch maximum (no minimum).

Rear Width: 39-inch minimum. 42-inch maximum

Wheelbase: 29 inches to 35.5 inches

Tires: MG SH, HZ, or HZi (Red) maximum circumference of 33-3/8 inches. Maximum tire pressure 30 PSI after race.

Only OEM Bodywork will be allowed.

Pushback bumpers are not required.

### 7.7.3 Engine

#### 7.7.3.1 Comer

Comer model C-50 or C-51 only

CC: 50

Minimum weight 150 lbs. (kart and driver)

Fixed Jet Carb, jet sizes 54 to 58.

Gear Ratio: 10/89 – 10-tooth engine sprocket with an 89-tooth rear sprocket. #219 chain

Pull Start

**Unaltered, STOCK MOTOR, clutch, exhaust, carb, etc.**

**NO MODIFICATIONS ARE LEGAL!!!**

**NO MOTOR TAPING ALLOWED!!!**

Air Filter is a non-tech item. No funneling allowed.

All air filters must be readily available to all competitors.

Must follow BKC 2-Cycle Fuel Rule (7.3.4.1 Gas and Oil).

**B.K.C  
By-Laws  
(2017 Revisions)  
BY-LAWS OF THE BADGER KART CLUB, INC.**

**Article I  
Name**

The name of the Corporation shall be Badger Kart Club, Inc. and shall hereinafter be referred to as the "Club."

**Article II  
Objectives and Scope**

The general objectives of the Club shall be as follows:

- A. The enjoyment and encouragement of Karting
  - B. To promote the highest standards of courtesy and safety
  - C. To promote and develop the highest standards of operation of a Kart and engine
  - D. To achieve excellence of performance through the sharing and exchange of mechanical and technical information
- The scope of the Club's endeavors shall be to achieve the stated objectives, promulgate the other By-Laws of the Club and articles stated in the Certificate of Incorporation issued to the Club under the statutes of the State of Wisconsin, as a not for profit corporation.

**Article III  
Offices**

The principal office of the club shall be in the State of Wisconsin at the facility known as Badger Raceway located at W377 S1851 Gramling Lane, Dousman, WI, 53118. The Club may have such other offices as the Board of Directors may determine.

**Article IV  
Membership**

**Section 1: Membership and Dues**

***Class I Membership:***

An individual/family consists of a person or an immediate family comprised of mother, father, children and or grandchildren with one full voting privilege.

***Class II Honorary Member:***

Any person who, by affirmative vote of  $\frac{3}{4}$  of the Board of Directors is deemed to merit recognition for outstanding contribution to the welfare of the Club. Such honorary membership shall be for a one-year period, subject to renewal by the board of Directors. An honorary member has full voting privileges.

***Class III Lifetime Honorary Member:***

Any person who, by affirmative vote of  $\frac{3}{4}$  of the Board of Directors is deemed to merit recognition for outstanding contribution to the welfare of the Club. This honorary member has full voting privileges until his/her death.

**Section 2: Membership**

Active memberships may be obtained upon receipt of the prospective member's application and the payment of all Club dues and fees as required by these By-Laws.

**Section 3: Membership Term**

The membership year shall run from January 1st thru December 31st of each year. Members whose dues and fees have not been paid by January 1st shall be automatically dropped from membership.

**Section 4: Termination of Membership**

The Board of Directors, by affirmative vote of  $\frac{2}{3}$  of all the members of the Board, may suspend or expel any member for cause after an appropriate hearing, and the decision of the Board shall be final.

**Section 5: Resignation**

Any member may resign by addressing a letter to the Club's secretary. Such resignation shall become effective upon receipt and all Club privileges shall terminate as of that date, with no refund of dues paid.

**Article V**  
**Meetings of Members**

**Section 1: Regular Meeting**

A regular bi-monthly meeting of the members shall be held for the purpose of transacting such business as shall come forth during the membership meeting on the 3rd Wednesday of each month designated for a meeting. Meetings will be held in January, March, May, July, September, and November.

**Section 2:**

The regular September meeting will be for the purpose of transacting such business as shall come before the meeting and for the express purpose of nominating officers and directors to serve for the ensuing year.

**Section 3:**

A special general membership meeting will be held prior to the annual awards banquet (time and place to be determined) for the express purpose of electing officers and directors to serve for the ensuing year. The new officers and directors will assume their duties upon being installed during the banquet ceremony.

**Section 4: Sequence of Election**

Officers and directors shall be elected in the following sequence:

1. President
2. Vice-President
3. Treasurer
4. Secretary
5. Sergeant-at-Arms
6. Directors

**Section 5: Special Meeting**

Special meetings of the members may be called by the President or by a majority of the Board of Directors.

**Section 6: Notice of Meeting**

No notice of regular monthly meetings of the members shall be required.

Notice of special meetings shall be given to all members in good standing, by a written notice, mailed not less than seven days prior to such meeting, and such notice shall state the place, date

and hour of such meeting and state the purposes or purpose for which the special meeting is called, and no business shall be transacted at such special meeting except that listed in the notice thereof.

**Section 7: Quorum**

No business may be transacted unless a minimum of 20% of the full-voting members are present, constitution a quorum.

**Section 8: Proxies**

At any meeting of members, a member entitled to vote, may vote by proxy executed in writing and duly notarized, or by his duly authorized representative, who shall also be a member in good standing. No proxy shall be valid except on the date designated in said proxy.

**Section 9: Method of Election**

Official ballots will be mailed to all members with voting privileges. Their ballots may be presented to the election committee on the night of election, or may be mailed to the election committee prior to election night, and will remain sealed until ballots are to be counted. The ballot mailed is the official ballot and no other will be provided.

**Article VI**  
**Board of Directors**

**Section 1: General Powers**

The Board of Directors, in accord with Club policy, shall manage the affairs of the Club as set down by the Articles of Incorporation, By-Laws, adopted resolutions of the membership and by the Statutes of the State of Wisconsin. The directors shall insure the proper conduct of the affairs of the Club, of the duties of the officers and compliance with the By-Laws.

**Section 2:**

The Board of Directors shall consist of 8 club members in good standing, plus the duly elected President to the BKC, who shall serve as Chairman of the Board.

**Section 3: Election and Term of Office**

Four of the directors of the Club shall be elected annually. The four persons receiving the most votes for directors by secret ballot along with the four

previously elected directors shall be elected directors to serve on the Board of Directors with the President during the ensuing year. Each director shall hold office for two years or until his successor shall have been elected and qualified.

#### Section 3.1: Attendance

A Board of Director's term of office will be subject to removal if the board member misses three meetings a year and does not attend at least 2/3 of the point's races. Board members are also required to attend at least one day of every special event; absence from such event will need prior Board approval.

#### Section 4: Regular Meetings

A regular meeting of the Board of Directors shall be held, without notice, on the first Wednesday of each month, at a place designated by the Chairman of the Board. A minimum of six (6) in-person meetings are required, with the remainder to be either conference call or in-person.

#### Section 5: Special Meeting

Special meetings of the Board of Directors may be called by or at the request of the President or any four directors.

#### Section 6: Notice of Special Board Meetings

Notice of special meetings shall be given to all members of the Board of Directors, by a written notice, mailed not less than four days prior to such meeting. The notice shall state the place, date and hour of such meeting and state the purposes or purpose for which the special meeting is called and no business shall be transacted at such special meeting except that listed in the notice thereof. Notice of such meeting may be waived in writing by any director and attendance of a director at any meeting shall constitute a waiver of notice for such meeting, except where such director appears to object to the validity of such meeting.

#### Section 7: Quorum

##### Section 7.1: Regular Board Meeting

A majority of the Board of Directors shall constitute a quorum for transaction of business at any meeting of the Board of Directors, but if less than a majority of directors are present at said meeting, a majority

of the directors present may adjourn the meeting from time to time without further notice.

#### Section 7.2: Special Board Meetings

A majority of the Board of Directors shall constitute a quorum for the transaction of business for the purpose for which the meeting was called as long as that majority favors waiving the required notice. If one of that majority constituting the quorum objects to waiving the notice, a quorum will cease to exist and the meeting will not take place.

#### Section 7.3: Proxies

A Board of Directors member may give another Board of Directors member a proxy to vote freely at a designated meeting. The proxy must include the date and have the date of the meeting on it. The proxy can either be hand written with a valid signature or sent through electronic mail.

#### Section 8: Vacancies

The next candidate receiving the highest votes from the previous election shall fill any vacancy occurring in the Board of Directors and any directorship to be filled by reason of an increase in the number of directors. A director designated shall fill the vacancy for the remaining term of his/her predecessor in office.

## **Article VII** **Officers**

#### Section 1: Officers

The officers of the corporation shall be a president, a vice-president, a secretary, a treasurer, and a sergeant-at-arms. No person may hold more than one (1) position in the corporation.

#### Section 2: Election and Terms of Office

The officers of the Club shall be elected annually. To be elected as an officer of the Club, a candidate must receive a majority of the votes cast for his or her particular office, with the vote to be by secret ballot. Each officer shall serve a two-year term. Voting alternates between President and Treasurer and Vice-President, Secretary, and Sergeant-at-Arms every other year.

#### Section 3: Vacancies

A vacancy in any office, except the office of President, because of death, resignation, removal,

disqualification or otherwise, may be filled by appointment of the Board of Directors for the remaining portion of the terms.

#### Section 3.1: Records

Upon termination of office, all records pertaining to Badger Kart Club shall be surrendered immediately to the Chairman of the Board of Directors.

#### Section 4: President

The President shall be the principal executive officer of the Club and shall in general supervise and control all of the business and affairs of the Club.

He shall preside at all meetings of the members and of the Board of Directors. He may sign with the secretary, or any other proper officer of the Club authorized by the Board of Directors, any deeds, mortgages, bonds, contract, check or other instruments which the Board of Directors have authorized to be executed, except in cases where the signing and execution thereof shall be expressly delegated by the Board of Directors or by these By-Laws or by the statute to some other officer or agent of the Club; and in general he shall perform all duties incident to the office of president and such other duties as may be prescribed by the Board of Directors from time-to-time.

#### Section 5: Vice President

In the absence of the President or in the event of his inability or refusal to act, the Vice President shall perform the duties of the President, and when so acting, shall have all the powers of and be subject to all the restrictions upon the President. The Vice President shall perform such other duties as from time-to-time may be assigned to him by the President or by the Board of Directors.

#### Section 6: Treasurer

The Treasurer shall have charge and custody of and be responsible for all funds and securities of the Club; receive and give receipts for monies due and payable to the Club from any source whatsoever, and deposit all such monies in the name of the Club in such banks, trust companies, or other depositories as shall be selected in accordance with the provision of Article IX of these By-Laws; and in general perform all the duties incident to the office of treasurer and such other duties as from time-to-

time may be assigned to him by the president or by the Board of Directors.

#### Section 7: Secretary

The Secretary shall keep the minutes of the meeting of the members and of the Board of Directors in one or more books provided for that purpose.

The Secretary shall also keep all records of votes and decisions made by the Board of Directors outside of the designated meeting times stated in these By-Laws. The Secretary shall see that all notices are duly given in accordance with the provisions of these By-Laws or as required by law; be custodian of the Club records; keep a register of the Post office address of each member and in general perform all duties incident to the office of secretary and such other duties as from time-to-time may be assigned by the President or by the Board of Directors.

#### Section 8: Sergeant-at-Arms

The Sergeant-at-Arms shall be duly elected by the membership of the Club and his duties shall be to maintain order at general meetings of the Club.

### **Article VIII** **Committees**

#### Section 1:

The President shall appoint the Chairperson of all committees and such other members, as the President shall deem proper. All appointments shall be brought to the Board for final approval. A 2/3rds majority of those present shall suffice. Organizational Charts consisting of the Officers and Executive board, Officers Committees and Autonomous Committees are attached.

### **Article IX** **Contracts, Checks, Deposits, and Funds**

#### Section 1: Contracts

The Board of Directors may authorize any office of officers, agents, or agent of the Club, in addition to the officers so authorized by these By-Laws, to enter into any contract or execute and deliver any instrument in the name of and on behalf of the Club, and such authority may be general or confined to specific instances.

#### Section 2: Checks, Drafts, etc.



All checks, drafts, or orders for the payment of money, notes, or other evidences of indebtedness issued in the name of the Club, shall be signed by such officer or officers, agent or agents of the Club and in such manner as shall from time-to-time be determined by resolution of the Board of Directors. In the absence of such determination by the Board of Directors, such instruments shall be signed by the treasurer and countersigned by the President.

#### Section 3: Deposits

All funds of the Club shall be deposited from time-to-time to the credit of the corporation in such banks, trust companies, or other depositories as the Board of Directors may select.

#### Section 4: Gifts

The Board of Directors may accept on behalf of the Club any contribution, gift, bequest, or devise for the general purposes or for any special purpose of the Club.

#### Section 5: Expenditures

Any non-ordinary expenditure exceeding \$1000 needs Board approval. A Board vote can be taken through electronic methods.

### **Article X** **Fiscal Year**

The fiscal year of the Club shall begin on the first day of January and end on the last day of December of each year.

### **Article XI** **Amendment of the By-Laws**

#### Section 1:

These By-Laws may be amended from time-to-time by a 2/3rds affirmative vote of the eligible voting members, at a regular or special meeting of the membership or by secure online voting with one vote per membership.

#### Section 2:

Proposed bylaw changes need to be detailed clearly to the President or a member of the Board of Directors. The President or a board member will send notice that the requested change will be voted on at the next General Membership meeting. The

notice will be via electronic mail to the club membership and will also be posted on the BKC web site a minimum of one week prior to the next scheduled General Membership meeting. If a quorum of 2/3rds of the eligible voting membership is not present at the membership meeting, the bylaw change will move to a secure online vote within one week of that meeting. The bylaw change will be emailed to the current membership email list for secure online voting. A 2/3rds affirmative vote of those who cast online votes is required to amend by bylaws.

### **Article XII** **Rules of Order**

Roberts Rules of Order shall govern the conduct of the meetings of the members and of the directors where such rules do not conflict with the Articles or By-Laws of the Club.

### **Article XIII** **Annual Rules Committee Procedures**

#### Section 1:

Each year the Rules Committee shall meet in one or more meetings to formulate new or revised competition rules for the forthcoming year.

#### Section 2:

Composition of the Rules Committee shall be as follows:

- Vice President – Chairperson
- All members of the Board of Directors
- The Secretary
- The previous year's Tech Chief
- The previous year's Race Director

Three volunteer members-at-large with the recommendation that one member-at-large be a representative of the four-cycle group. If more than three members-at-large come forth, the Board of Directors will determine by a majority vote who will serve.

#### Section 3.1:

The first annual rules committee meeting will be held between July 15th and the August Board of Directors meeting of each year. The report of the Rules Committee must be presented in a mailing to the membership the following September.

### Section 3.2:

The September General Membership meeting will include only a review and discussion of the proposed rule changes. Counter-proposals must be submitted to the Rules Committee Chairman in writing with 5 (Members Only) verifiable signatures (either written or electronic) for Board approval prior to this meeting. Any and all counter-proposals must be submitted on a BKC Counter-proposal form ONLY. If approved by the Board any and all counter-proposals will be presented in a mailing to the membership the following November.

### Section 3.3:

The final Annual Rules Meeting will be held in November of each year. At that time the membership will cast their vote for or against the Rule Committee's proposals, amendment, deletions and counter-proposals received. No discussion or review will be held at this meeting.

### Section 3.4:

Those members unable to attend the Annual Rules Meeting in November may forward their vote for or against any proposal made by the Rules Committee or any other amendment, deletion, or counter proposal received and mailed to the membership in either October or November. This vote must be postmarked to the membership chairperson no later than the second Wednesday of November.

### Section 4:

The report of the Rules Committee shall be the basis for the agenda of the Annual Rules Meeting. The procedure shall be as follows:

1. Each proposed new rule, amended rule, counter-proposal of a rule, or rule to be deleted shall first be read. A 2/3rds majority of the voting membership present, including those cast by mail, shall suffice for adoption of the new rule, amendment, counter-proposal, or rule deletion.

2. No written or verbal modification from the floor to any proposed rule, amendment, counter-proposal, or rule deletion will be allowed.

3. When the last item of business of the Annual Rules Meeting has been disposed of, the Chairperson will say: "Do I hear a motion to adopt those rules still standing from the previous year together with those adopted in Item 1, Section 4, as

the rules for the Badger Kart Club, Inc. for the year (Current)?" If seconded, a vote of those members present will be taken; a 2/3rds majority is needed for the motion to pass. The Chairperson will rule as to whether a 2/3rds majority of the voting membership has been achieved.

### Section 5:

The rules as adopted at the Annual Rules Meeting shall be published within sixty (60) days of the meeting and distributed to all members of record. A sufficient supply of additional rulebooks shall be on hand thereafter for subsequent distribution to new and renewed members.

### Section 6:

Upon the rules pertaining to "Class Requirements" having been voted on and passed by the membership they cannot be changed for one full season of that competition year except for a Board of Directors decision pertaining to the financial and safety status of the Club.

# TRACK SESSION RECORD

Driver		Kart		Track		Best Lap	
Date	Time/Heat		Laps	<input type="radio"/> Practice <input type="radio"/> Qualifying <input type="radio"/> Race		Peak RPM	
Weather		Air Temp		Track Temp		Tires	
Gear Ratio		Clutch		Springs		Weight	
Motor		Header		Plug		Main Jet	
						Idle Jet	

LF Caster		LF Camber	
LF Weight		Spacers	
LF Pressure Hot		Cold	
Tire Temp			

RF Caster		RF Camber	
RF Weight		Spacers	
RF Pressure Hot		Cold	
Tire Temp			

LR Weight		LR Hub Spacing	
LR Pressure Hot		Cold	
Tire Temp			

Chassis Weight			
Chassis & Driver			
Balance F-R %		L-R %	
Cross Wts. LF-RR%		RF-LR%	
Toe	Ft. Track	Rr. Track	

RR Weight		RR Hub Spacing	
RR Pressure Hot		Cold	
Tire Temp			

Chassis	
Ft. Torsion <input type="radio"/> Tight <input type="radio"/> Loose <input type="radio"/> Off	
Rr. Torsion <input type="radio"/> Tight <input type="radio"/> Loose <input type="radio"/> Off	
Nerf Bars <input type="radio"/> Tight <input type="radio"/> Loose <input type="radio"/> Off	
Sidepods <input type="radio"/> Tight <input type="radio"/> Loose	
Ft. Bumper <input type="radio"/> Tight <input type="radio"/> Loose	
Seat Stays <input type="radio"/> 2 <input type="radio"/> 3 <input type="radio"/> 4	
Seat Pos.	
Seat Angle	
Axle Diameter	
Axle Stiffness	
# Rear Bearings <input type="radio"/> 2 <input type="radio"/> 3	
Rear Axle Pos. <input type="radio"/> High <input type="radio"/> Low	
Front Spindle Pos. <input type="radio"/> High <input type="radio"/> Low	
Brake Pads	
Brake Rotor	

	Lap Time	Max RPM	Min RPM	Notes
Lap 1				
Lap 2				
Lap 3				
Lap 4				
Lap 5				
Lap 6				
Lap 7				
Lap 8				
Lap 9				
Lap 10				
Lap 11				
Lap 12				
Lap 13				
Lap 14				
Lap 15				

 **DAVIDHOBBS**

A DEALER



WE BELIEVE THAT EVERYONE DESERVES TO

DRIVE A **NICER, NEWER CAR.**

So we are:-

**PUTTING THE FUN BACK IN BUYING A CAR,**

**BRINGING TRANSPARANCY TO THE INDUSTRY**

**SOLVING YOUR AUTOMOTIVE NEEDS**

'For the People' Pledge.

*We are a Dealer **for** the people. That means we put our customers first, before everything else. We believe that everyone deserves to drive a nicer newer car today.*

*Our business is not selling cars. Our business is finding solutions to the everyday problems that keep most people stuck in a car they hate.*

*We are on a mission to change the world by helping people get the car they want and deserve.*

*My goal is to be a trusted advisor in the process.*

*Call us today and find out what a difference we can make.*

**Hobbsforthepeople.com**

**800-721-8131**

**6100 N. Green Bay Ave, Glendale, WI. 53209**

**Franklin**  
www.franklinkart.com

THE CHOICE  
OF CHAMPIONS.

PHOTO BY  
KATHY CHURCHILL

Franklin Motorsports is everything you need in a kart shop. Our comprehensive online store stocks the highly-tunable **MERLIN** kart chassis line, **TILLETT**'s high-performance racing seats, **DRIVELINE** kart components, varieties of racing tires, and everything else you need to stand on top of the podium. Franklin Motorsports attends several events annually with a fully stocked mobile store, offering parts and technical services as well as full arrive and drive programs. Add all these services together and it's easy to see why so many champions have chosen Franklin Motorsports for their karting needs.



PHONE: 262-814-5400  
EMAIL: info@franklinkart.com  
WEB: www.franklinkart.com

**Franklin**  
www.franklinkart.com



# Our Partner Series

## CUP KARTS NORTH AMERICA



206 Kid Karts (5-8)  
 206 Cadet (8-10)  
 206 Sportsman (10-13)  
 206 Junior (12-15)  
 206 Senior Light  
 206 Senior Medium (15+)  
 206 Senior Heavy (15+)  
 206 Masters (35+)  
 206 Legends (50+)

April 21 – 23 Motorsports Club of Cincinnati, OH

May 19 – 21 Autobahn Country Club, Joliet, IL

**June 16 – 18 Badger Kart Club  
 Dousman, WI**

July 21 – 23 Whiteland Raceway Park, Whiteland, IN

Sept. 28 – Oct. 1 New Castle Motorsports Park, New Castle, IN

<http://www.cupkarts.com/>



Kid Kart (5-8)  
 IAME Micro Swift (7-10)  
 IAME Mini Swift (8-12)  
 IAME KA100 Junior (12-15)  
 IAME KA100 Senior (15+)  
 IAME KA100 Masters (30+)  
 Briggs 206 Sportsman (7-12)  
 Briggs 206 Junior (12-15)  
 Briggs 206 Senior Medium (15+)  
 Briggs 206 Senior Heavy (15+)

May 19 – 21 New Castle Motorsports Park, New Castle, IN

July 7 – 9 Road America Kart Club, Elkhart Lake, WI

August 11 – 13 Whiteland Raceway Park, Whiteland, IN

**Sept. 8 – 10 Badger Kart Club  
 Dousman, WI**

<http://www.route66kartracing.com/>



# 2023 Badger Kart Club Schedule

## at Mill-Rite Raceway

### February

19<sup>th</sup> BKC Swap Meet at David Hobbs Honda

### April

1<sup>st</sup>-2<sup>nd</sup> Track Setup Saturday, Sunday Practice for Setup Volunteers

8<sup>th</sup>-9<sup>th</sup> Track Closed

16<sup>th</sup> Non-Points Race

23<sup>rd</sup> Non-Points Race

30<sup>th</sup> Points Race #1 **Qualify**

### May

7<sup>th</sup> Points Race #2 **Qualify** **TaG Masters**

14<sup>th</sup> Points Race #3 **Qualify**

20<sup>th</sup> – 21<sup>st</sup> Track Closed

26<sup>th</sup> – 28<sup>th</sup> Track Closed for Memorial Day

### June

4<sup>th</sup> Points Race #4 (JSS #1) **206 & TaG Masters**

10<sup>th</sup> (Sat.) Points Race #5 (JSS #2)

11<sup>th</sup> Points Race #6 (JSS #3) **Qualify**

16<sup>th</sup> – 18<sup>th</sup> Cup Karts North America at Mill-Rite Raceway

23<sup>rd</sup> – 24<sup>th</sup> Track Closed

30<sup>th</sup> Cheesehead Challenge at Road America (Track Closed)

### July

1<sup>st</sup> – 2<sup>nd</sup> Cheesehead Challenge at Road America (Track Closed)

4<sup>th</sup> – 9<sup>th</sup> Track Closed for 4<sup>th</sup> of July

16<sup>th</sup> Points Race #7 (JSS #4) **TaG Masters**

21<sup>st</sup> – 23<sup>rd</sup> Track Closed

29<sup>th</sup> (Sat.) Points Race #8 (JSS #5)

30<sup>th</sup> Points Race #9 (JSS #6) **Qualify** **206 & TaG Masters**

### August

4<sup>th</sup> – 6<sup>th</sup> Cheesehead Challenge at Mill-Rite Raceway

11<sup>th</sup> – 13<sup>th</sup> Track Closed

20<sup>th</sup> Points Race #10 (JSS #7)

26<sup>th</sup> Dairyland 8-Hour Endurance Race at Mill-Rite Raceway

27<sup>th</sup> Points Race #11 (JSS #8) **Qualify** **TaG Masters**

### September

1<sup>st</sup> – 3<sup>rd</sup> Track Closed for Labor Day

8<sup>th</sup> – 10<sup>th</sup> Route 66 Sprint Series at Mill-Rite Raceway

17<sup>th</sup> Points Race #12

24<sup>th</sup> Points Race #13 **Qualify** **206 & TaG Masters**

### October

1<sup>st</sup> Non-Points Race

8<sup>th</sup> Points Race #14 **206 & Tag Masters Rain Date**

15<sup>th</sup> Non-Points Race

22<sup>nd</sup> Non-Points Race

28<sup>th</sup>

### November

11<sup>th</sup> Awards Banquet at Marriott West Waukesha



Classic Track

National Track



Bus-Stop Track



National Track



For 2023, the best 12 out of 14 finishes will count toward BKC series points.

JSS = Junior Summer Series (for info: [www.badgerkartclub.com/jss.html](http://www.badgerkartclub.com/jss.html))

TRACK HOURS Wednesday, Thursday, & Friday 10am – 7pm; Saturday & Sunday 10am – 6pm **TRACK CLOSED EVERY MONDAY & TUESDAY**

DIRECTIONS: I-94 west from Milwaukee to HWY-67 exit, HWY-67 south to HWY-18; HWY-18 west to Wolf Paving Raceway sign; south on Gramling lane to the track entrance. **TRACK TELEPHONE:** (262) 836-4252. For membership information visit our web site: [www.badgerkartclub.com](http://www.badgerkartclub.com)



Championship Points Series

**MILL-RITE**

**RACEWAY**

**DAVID HOBBS Honda**  
DEALER FOR THE PEOPLE

**SOURCE**  
RACING ENGINES  
414-541-7710

**WINTER SERVICES**  
2100 S. 116th St.  
West Allis, WI 53226  
866-SNOW-ICE (766-9423)

**Advance Design**  
studio, ltd  
COMMON SENSE REMODELING

**TEAM SWISS**

**Signarama**  
Downtown  
The way to grow your business.  
414-273-7446  
www.milwaukee-signs.com  
SIGNS • SCREEN • EMBROIDERY

**NKS**  
**National Kart Supply**  
Developed to win...  
With no compromises!  
www.nationalkartsupply.com  
877-89-HAASE (4-2273)

**Franklin**  
www.franklinkart.com  
**MERLIN**  
2785 S 167th St  
New Berlin, WI 53151  
262-814-5400

**Julien**  
**SHADE SHOP INC.**  
414-271-3864  
2242 S. 116th St.  
West Allis, WI

**WPK**  
WILL POWER KART

**MILLS PALLET, INC**

**kw** MILWAUKEE NORTH SHORE  
KELLER WILLIAMS  
**Andrea J Crivello**  
The Racing Agent  
www.TheRacingAgent.com  
414-807-5851  
Each Keller Williams Realty Office is Independently Owned and Operated

**NORTHERN**  
AIR SYSTEMS, INC.  
847-223-8877  
Heating  
Cooling  
Grayslake, IL